

ISOMETRIC: TOP

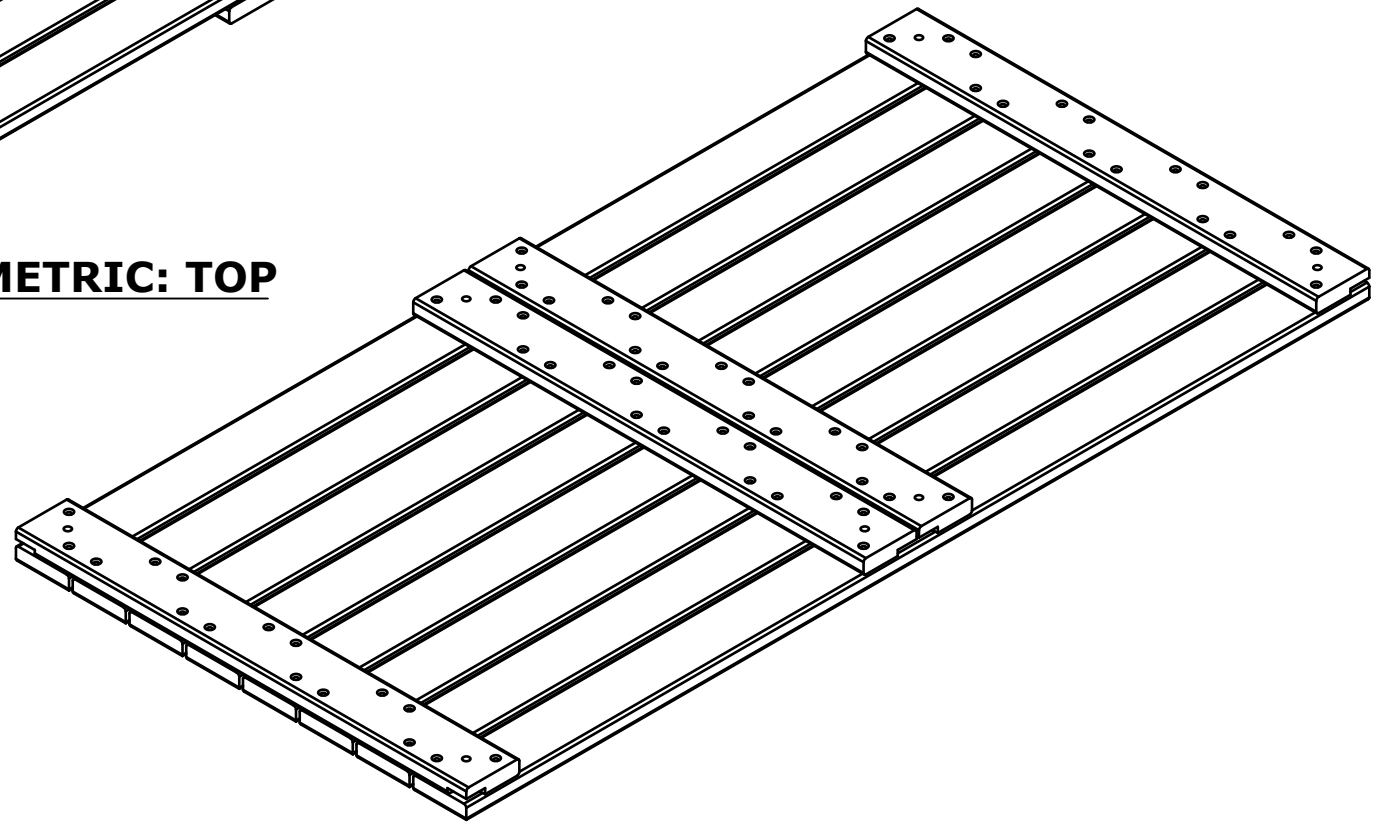

ISOMETRIC: BOTTOM

- 1) REGARDLESS OF WOOD SPECIES, ALL WOOD MATERIALS USED IN THE PRODUCTION OF TILES MUST BE PREMIUM SELECT ARCHITECTURAL GRADE AS PER TFP GRADING RULES INCLUDING ALLOWABLE SLOPE OF GRAIN.
- 2) ALL SLATS USED IN THE PRODUCTION OF BLACK LABEL DECK TILES MUST BE FREE FROM REVERSE GRAIN.
- 3) ALL WOOD MATERIALS USED IN THE PRODUCTION OF BLACK LABEL DECK TILES MUST BE KILN DRIED TO A MOISTURE CONTENT BETWEEN 12 AND 14%.
- 4) ALL SCREWS USED IN THE PRODUCTION OF WOOD DECK TILES MUST BE STAINLESS STEEL 305 OR 316 GRADE.
- 5) ALL BUTT ENDS OF DECK SLATS MUST HAVE A RADIUS AS PER PRODUCTION DRAWINGS.
- 6) ALL BUTT ENDS OF DECK SLATS MUST BE END SEALED WITH A WAX SOLUTION. THERE MUST BE NO END WAX ON THE FACE OF DECK SLATS.
- 7) ALL DECK TILES MUST BE PACKAGED AS PER TROPICAL FOREST PACKAGING SPECIFICATIONS
- 8) ALL DECK TILES MUST BE MARKED BY INK STAMP OR STICKER 'KILN DRIED / PRODUCT OF BRAZIL'

DT2448
Deck Tile 1.5 Thick 24 Wide x 48 Long (net 23 7/8 x 47 7/8)

Sheet#: 1
REV# 1
ISSUE DATE: 2/22/2022
TFP3261003.idw