

# TROPICAL

## TROPICAL FOREST PRODUCTS CLAD CLIP™ GUIDE DETAILS: HORIZONTAL RAINSCREEN ATTACHMENT W/ KNIGHT WALL CI™ SYSTEM (VERTICAL CI-GIRT ONLY)

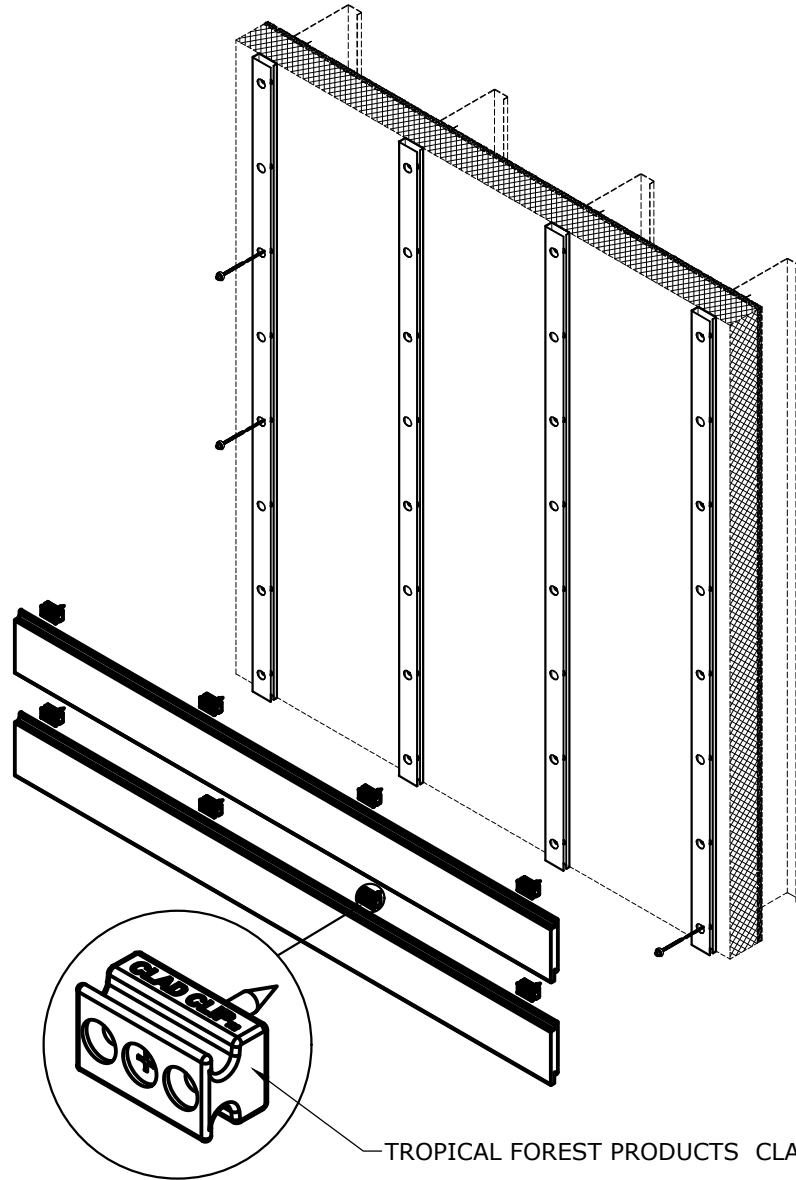

### TFP HORIZONTAL APPLICATION

#### VERTICAL ORIENTATED GIRT ONLY

SYSTEM DEPTH W/ TROPICAL FOREST PRODUCTS RAINSCREEN™ & TROPICAL FOREST PRODUCTS CLAD CLIP™: W/ CI GIRT: 1" RAINSCREEN = 1.875", 5/4" RAINSCREEN = 2"

W/ CI GIRT 150: 1" RAINSCREEN = 2.625", 5/4" RAINSCREEN = 2.75"

(FACE OF RIGID INSULATION TO FACE OF RAINSCREEN)

THESE GUIDE DETAILS ARE PROVIDED FOR INFORMATION ONLY AND OUTLINE GENERAL/TYPICAL REQUIREMENTS FOR THE ATTACHMENT SYSTEM. PROJECT SPECIFIC ENGINEERING WILL ADDRESS STRUCTURAL ATTACHMENT (I.E. FASTENING PATTERN, ETC.). CONTACT KWS FOR FURTHER DETAILS. ALL IMPLIED WARRANTIES INCLUDING MERCHANTABILITY & FITNESS FOR A PARTICULAR PURPOSE ARE EXPRESSLY EXCLUDED.

# TROPICAL

## TROPICAL FOREST PRODUCTS RAINSCREEN GENERAL NOTES:

- TROPICAL FOREST PRODUCTS IS NOT RESPONSIBLE FOR INFORMATION SHOWN ON ALL DETAILS BEYOND SPECIFIC SCOPE OF WORK (INDICATED AS TFP RAIN SCREEN OR VANISH RAIN SCREEN CLIPS).
- CONSULT TFP MASTER PLAN SHEET FOR ENGINEER SEALED SYSTEM DETAILS
- DETAILS ARE ONLY TO COMMUNICATE HOW TFP RAIN SCREEN CAN BE USED WITH KNIGHT WALL SYSTEMS.
- DETAILS OF ADJACENT WORK ARE SHOWN FOR COMPLETENESS, CLARITY AND CONVENIENCE AS AN EXAMPLE BUILT ENVIRONMENT ONLY.
- THE STRUCTURAL SUPPORT, BACK-UP WALL AND SUPER STRUCTURE DESIGN IS WITH OTHER PARTIES NOT LIMITED TO, STEEL STUD WALL, etc.). THE RESPONSIBILITY FOR THESE OTHER ASSEMBLIES TO ACCOMMODATE ALL LOADS IMPOSED UPON THEM BY TFP RAIN SCREEN, SHOULD BE CONSIDERED.
- SOFT JOINTS, SEALANT AND FLASHING SPECIFICATIONS, DESIGN AND INSTALLATION ARE WITH OTHER PARTIES
- WEATHER RESISTANT/AIR BARRIER AND INSULATION SPECIFICATIONS, DETAILING AND INSTALLATION, PENETRATIONS, ARE WITH OTHER PARTIES.
- TROPICAL FOREST PRODUCTS HAS SELECTED FASTENER AND CLIP METAL GRADES DESIGNED TO REDUCE GALVANIC REACTION. POTENTIAL GALVANIC REACTION ALWAYS EXISTS AT SOME LEVEL WHEN DISSIMILAR METALS ARE IN CONTACT. POTENTIAL GALVANIC REACTION MUST ALSO BE CONSIDERED WHEN METALS ARE IN CONTACT WITH CHEMICALLY TREATED LUMBER
- USE FINISH WOOD BLADES FOR CUTTING WOOD RAIN SCREEN COMPONENTS.
- APPLY ANCHORSEAL TO ALL FRESHLY CUT ENDS OF RAIN SCREEN BOARDS.
- USE OF IMPACT DRIVERS IS NOT RECOMMENDED WHEN DRIVING ANY FASTENER FOR THE SYSTEM.
- THE DETAILS WITHIN THIS DRAWING PACKAGE ARE NOT INTENDED TO REPLACE PROJECT SPECIFIC ENGINEERING CALCULATIONS OR THE DESIGN SERVICES OF A REGISTERED PROFESSIONAL DESIGNER AND ARE SUBJECT CHANGE AT ANY TIME. PROJECT SPECIFIC ENGINEERING PROVIDED BY OTHERS.
- NO FREEDOM FROM ANY PATENT OWNED BY TROPICAL FOREST PRODUCTS OR OTHERS IS TO BE INFERRED. BECAUSE USE CONDITIONS AND APPLICABLE DIFFER FROM ONE LOCATION TO ANOTHER AND MAY CHANGE WITH TIME, CUSTOMER IS RESPONSIBLE FOR DETERMINING WHETHER PRODUCTS AND THE INFORMATION DOCUMENT ARE APPROPRIATE FOR CUSTOMER'S USE AND FOR ENSURING THAT THE CUSTOMER'S WORKPLACE AND DISPOSAL PRACTICES ARE IN COMPLIANCE WITH APPLICABLE AND OTHER GOVERNMENT ENACTMENTS. TROPICAL FOREST PRODUCTS ASSUMES NO OBLIGATION OR LIABILITY FOR THE INFORMATION CONTAINED IN THIS DOCUMENT
- NO EXPRESS WARRANTIES ARE GIVEN EXCEPT FOR ANY APPLICABLE WRITTEN LIMITED WARRANTIES SPECIFICALLY PROVIDED BY TROPICAL FOREST PRODUCTS. ALL IMPLIED WARRANTIES INCLUDING THOSE OF MERCHANTABILITY AND FITNESS FOR A PARTICULAR PURPOSE ARE EXPRESSLY EXCLUDED
- BUILDING AND/OR CONSTRUCTION PRACTICES UNRELATED TO BUILDING MATERIALS COULD GREATLY AFFECT MOISTURE AND THE POTENTIAL FOR MOLD FORMATION. NO MATERIAL SUPPLIER INCLUDING TROPICAL FOREST PRODUCTS CAN GIVE ASSURANCE THAT MOLD WILL NOT DEVELOP.

THESE GUIDE DETAILS ARE PROVIDED FOR INFORMATION ONLY AND OUTLINE GENERAL/TYPICAL REQUIREMENTS FOR THE ATTACHMENT SYSTEM. PROJECT SPECIFIC ENGINEERING WILL ADDRESS STRUCTURAL ATTACHMENT (i.e. FASTENING PATTERN, ETC.). CONTACT KWS FOR FURTHER DETAILS. ALL IMPLIED WARRANTIES INCLUDING MERCHANTABILITY & FITNESS FOR A PARTICULAR PURPOSE ARE EXPRESSLY EXCLUDED.



# TROPICAL

## TABLE OF CONTENTS

1. TITLE PAGE
2. TROPICAL FOREST PRODUCTS RAINSCREEN GENERAL NOTES
3. TABLE OF CONTENTS
4. TROPICAL FOREST PRODUCTS RAINSCREEN HORIZONTAL ATTACHMENT TO KNIGHTWALL
5. TROPICAL FOREST PRODUCTS RAINSCREEN CLAD CLIP DETAILS
6. LAYUP DIMENSIONS TFP RAINSCREEN: 1" WITH NO REVEAL
7. LAYUP DIMENSIONS TFP RAINSCREEN: 1" WITH  $\frac{1}{8}$ " REVEAL
8. LAYUP DIMENSIONS TFP RAINSCREEN: 1" WITH  $\frac{1}{4}$ " REVEAL
9. LAYUP DIMENSIONS TFP RAINSCREEN: 1" WITH  $\frac{1}{2}$ " REVEAL
10. LAYUP DIMENSIONS TFP RAINSCREEN: 5/4" WITH NO REVEAL
11. LAYUP DIMENSIONS TFP RAINSCREEN: 5/4" WITH  $\frac{1}{8}$ " REVEAL
12. LAYUP DIMENSIONS TFP RAINSCREEN: 5/4" WITH  $\frac{1}{4}$ " REVEAL
13. LAYUP DIMENSIONS TFP RAINSCREEN: 5/4" WITH  $\frac{1}{2}$ " REVEAL
14. TYPICAL SECTION VIEW - HORIZONTAL RAINSCREEN / VERTICAL CI-Girt ONLY
15. TYPICAL PLAN VIEW - HORIZONTAL RAINSCREEN / VERTICAL CI-Girt ONLY
16. TYPICAL SECTION VIEW - HORIZONTAL RAINSCREEN / VERTICAL CI-GIRT 150 ONLY
17. TYPICAL PLAN VIEW - HORIZONTAL RAINSCREEN / VERTICAL CI-GIRT 150 ONLY
18. TYPICAL OUTSIDE CORNER - HORIZONTAL RAINSCREEN / VERTICAL CI-Girt ONLY
19. TYPICAL INSIDE CORNER - HORIZONTAL RAINSCREEN / VERTICAL CI-Girt ONLY
20. TYPICAL JAMB CONDITION - HORIZONTAL RAINSCREEN / VERTICAL CICI-Girt ONLY
21. TYPICAL HEAD/SILL CONDITION - HORIZONTAL RAINSCREEN / VERTICAL CI-Girt ONLY
22. TYPICAL BASE OF WALL CONDITION - HORIZONTAL RAINSCREEN / VERTICAL CI-Girt ONLY
23. TYPICAL FLOOR DEFLECTION JOINT - HORIZONTAL RAINSCREEN / VERTICAL CI-Girt ONLY
24. KNIGHT WALL GENERAL NOTES
25. ISOMETRIC VIEW OF COMPONENTS BY KNIGHT WALL (KWS)

PLEASE FEEL FREE TO CONTACT TROPICAL FOREST PRODUCTS FOR PROJECT SPECIFIC ASSISTANCE WITH TFP® CLADDING OPTIONS AND SPECIFIC ASSISTANCE.

905.672.8000 OR 855.344.4500

[info@wearetropical.com](mailto:info@wearetropical.com)

THESE GUIDE DETAILS ARE PROVIDED FOR INFORMATION ONLY AND OUTLINE GENERAL/TYPICAL REQUIREMENTS FOR THE ATTACHMENT SYSTEM. PROJECT SPECIFIC ENGINEERING WILL ADDRESS STRUCTURAL ATTACHMENT (I.E. FASTENING PATTERN, ETC.). CONTACT KWS FOR FURTHER DETAILS. ALL IMPLIED WARRANTIES INCLUDING MERCHANTABILITY & FITNESS FOR A PARTICULAR PURPOSE ARE EXPRESSLY EXCLUDED.



# TROPICAL

## CLAD CLIP SPECS

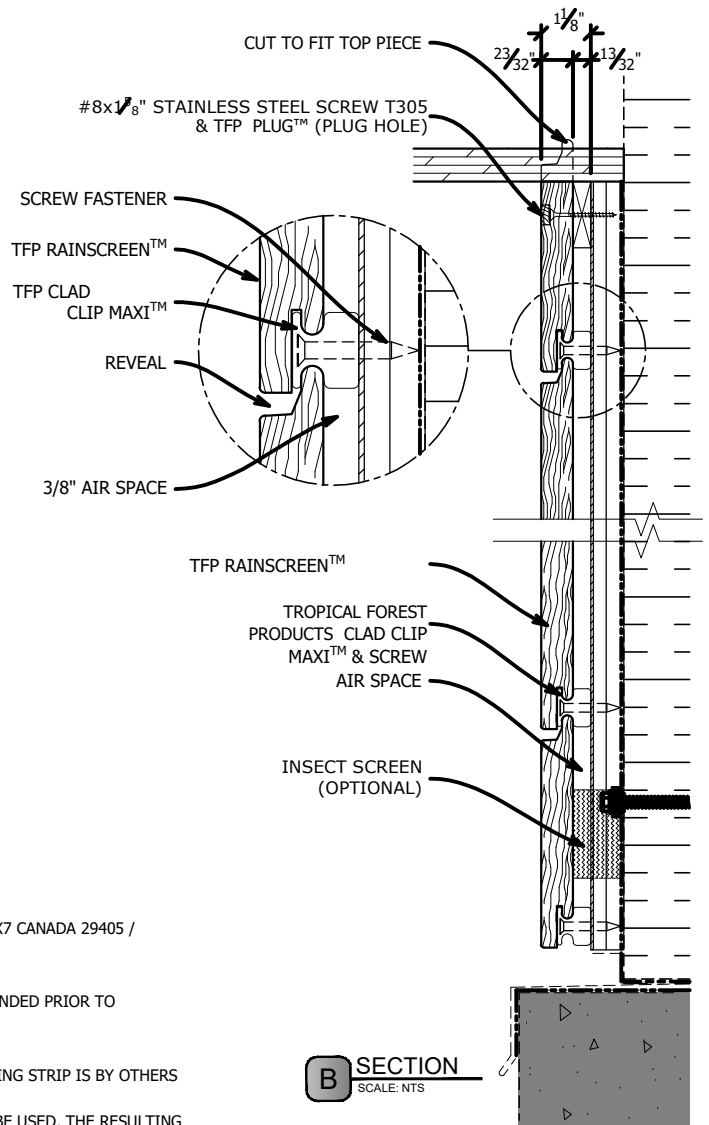
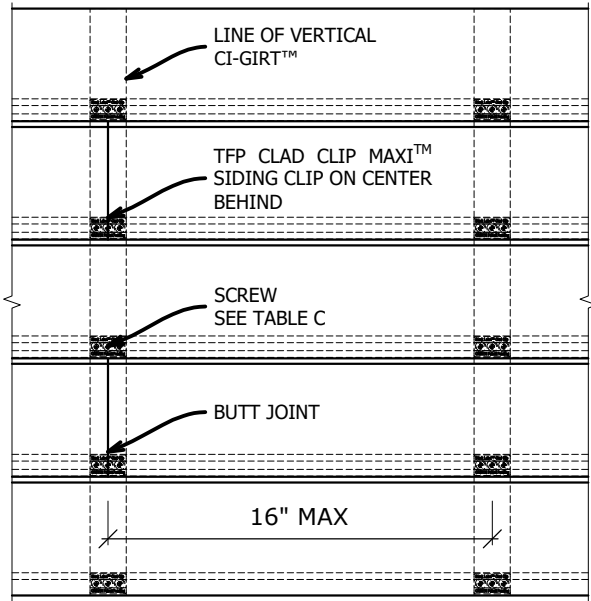

**A** ELEVATION  
SCALE: NTS

### NOTES

1. BASIS OF DESIGN - TFP® RAINSCREEN SYSTEM - ADDRESS: 6200 TOMKEN RD, MISSISSAUGA, ON L5T 1X7 CANADA 29405 / PHONE: 905.672.8000
2. TFP® CLADDING - WOOD SPECIES AS DENOTED IN PLANS AND SPECIFICATIONS
3. APPLICATION OF FIRST COAT OF TFP IPE + MARINE OIL TO ALL FACES OF WOOD CLADDING RECOMMENDED PRIOR TO CLADDING INSTALLATION
4. USE #10 X 1.25" 410 STAINLESS STEEL SELF DRILLING FLAT HEAD SCREW SUPPLIED BY TFP
5. IF METAL FURRING STRIPS ARE USED, USE #10 X 3/4" SCREW. ATTACHMENT AND INTEGRITY OF FURRING STRIP IS BY OTHERS AND SHALL MEET ALL IMPOSING LOADS, METAL FURRING MUST BE 18 GA MINIMUM.
6. NOTE: IF A LESSER DIAMETER SCREW OR OTHER THAN MANUFACTURE'S SCREW TYPE IS DESIRED TO BE USED, THE RESULTING PRESSURES AND SPACING WILL CHANGE. THE PERMUTATIONS OF THESE OPTIONS IS OUTSIDE THE SCOPE OF THIS PLAN.
7. ALL WORK SPECIFIED HEREIN HAS BEEN DESIGNED AND SHALL BE FABRICATED IN ACCORDANCE WITH THE FLORIDA BUILDING CODE FIFTH EDITION (2014)
8. ALL MATERIALS USED & FABRICATION METHODS SHALL CONFORM TO THE MANUFACTURER'S PUBLISHED AND APVED REQUIREMENTS.
9. ALL FASTENERS TO BE STAINLESS STEEL.

**B** SECTION  
SCALE: NTS

| SIDING SIZES | TYPE OF CONNECTION    | PANEL/FURRING THICKNESS | CLIP SPACING | CLIP TYPE | SCREWS PER CLIP | SCREW      | ALLOWABLE PRESSURE |
|--------------|-----------------------|-------------------------|--------------|-----------|-----------------|------------|--------------------|
| 1" X 6"      | CLIP TO STEEL FURRING | 16 GA                   | 16"          | MAXI      | 1 PCS.          | #10 X 1.25 | 110.0 PSF          |
| 1" x 4"      | CLIP TO STEEL FURRING | 16 GA.                  | 16"          | MAXI      | 1 PCS.          | #10 X 1.25 | 110.0 PSF          |

**C** RAINSCREEN ATTACHMENT TABLE  
SCALE: NTS

THESE GUIDE DETAILS ARE PROVIDED FOR INFORMATION ONLY AND OUTLINE GENERAL/TYPICAL REQUIREMENTS FOR THE ATTACHMENT SYSTEM. PROJECT SPECIFIC ENGINEERING WILL ADDRESS STRUCTURAL ATTACHMENT (I.E. FASTENING PATTERN, ETC.). CONTACT KWS FOR FURTHER DETAILS. ALL IMPLIED WARRANTIES INCLUDING MERCHANTABILITY & FITNESS FOR A PARTICULAR PURPOSE ARE EXPRESSLY EXCLUDED.

# TROPICAL

## TFP CLAD CLIP™ DETAILS SCALE: FULL

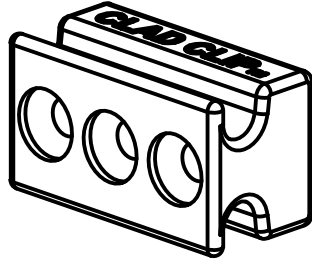

**ISOMETRIC**

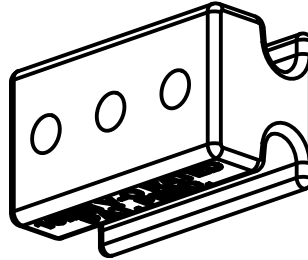

**REAR ISOMETRIC**

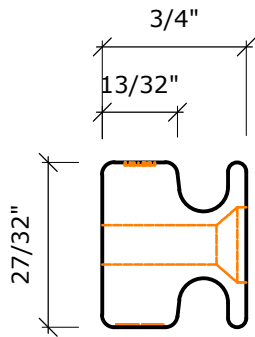

**SIDE VIEW**

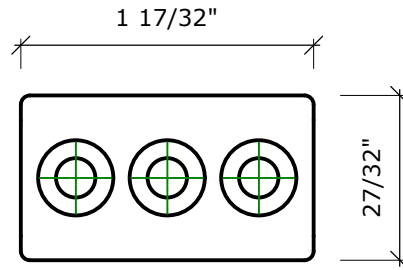

**FRONT VIEW**

**A** TFP CLAD CLIP MAXI - BLCCMAX10MMVO  
SCALE: NTS

TROPICAL FOREST PRODUCTS COPYRIGHT 2021

THESE GUIDE DETAILS ARE PROVIDED FOR INFORMATION ONLY AND OUTLINE GENERAL/TYPICAL REQUIREMENTS FOR THE ATTACHMENT SYSTEM. PROJECT SPECIFIC ENGINEERING WILL ADDRESS STRUCTURAL ATTACHMENT (I.E. FASTENING PATTERN, ETC.). CONTACT KWS FOR FURTHER DETAILS. ALL IMPLIED WARRANTIES INCLUDING MERCHANTABILITY & FITNESS FOR A PARTICULAR PURPOSE ARE EXPRESSLY EXCLUDED.

# TROPICAL

## LAYUP DIMENSIONS - 1" WITH NO REVEAL SCALE: NTS

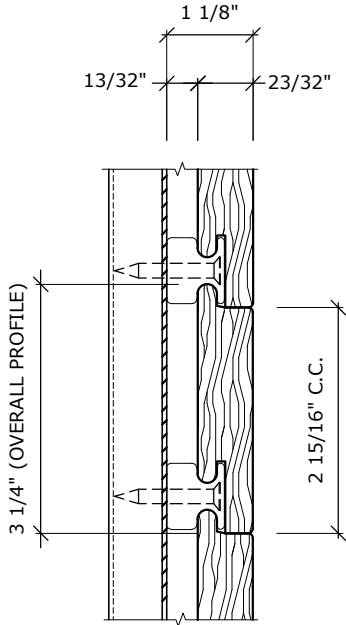

**A** TFP CLAD CLIP MAXI w/ 1" X 4" 1/4 NO REVEAL RAINSCREEN  
SCALE: NTS

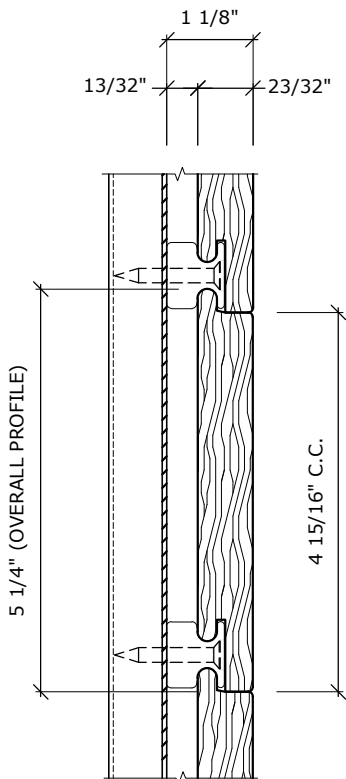

**B** TFP CLAD CLIP MAXI w/ 1" X 6" 1/4 NO REVEAL RAINSCREEN  
SCALE: NTS

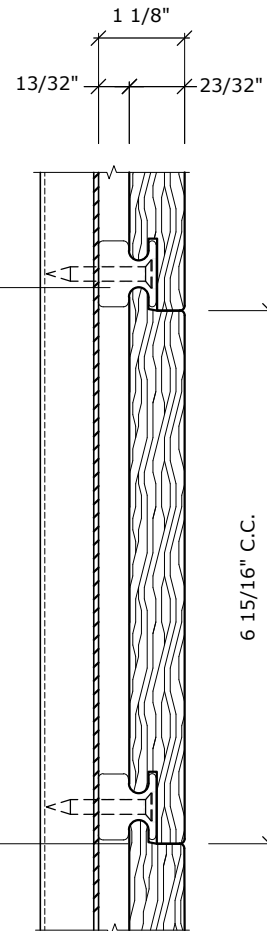

**C** TFP CLAD CLIP MAXI w/ 1" X 8" 1/4 NO REVEAL RAINSCREEN  
SCALE: NTS

THESE GUIDE DETAILS ARE PROVIDED FOR INFORMATION ONLY AND OUTLINE GENERAL/TYPICAL REQUIREMENTS FOR THE ATTACHMENT SYSTEM. PROJECT SPECIFIC ENGINEERING WILL ADDRESS STRUCTURAL ATTACHMENT (I.E. FASTENING PATTERN, ETC.). CONTACT KWS FOR FURTHER DETAILS. ALL IMPLIED WARRANTIES INCLUDING MERCHANTABILITY & FITNESS FOR A PARTICULAR PURPOSE ARE EXPRESSLY EXCLUDED.

TROPICAL FOREST PRODUCTS COPYRIGHT 2021



# TROPICAL

## LAYUP DIMENSIONS - 1" WITH 1/8" REVEAL SCALE: NTS

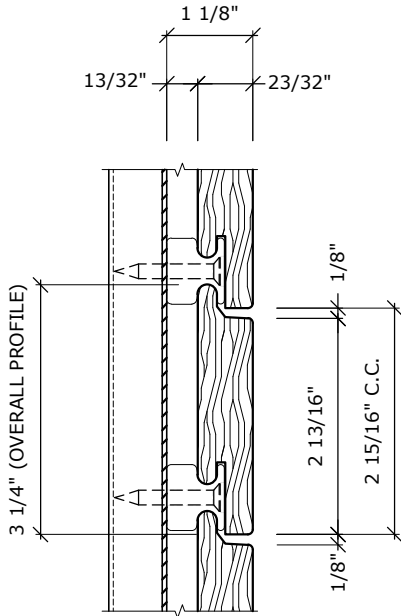

**A** TFP CLAD CLIP MAXI w/ 1" X 4" 1/8 REVEAL RAINSCREEN  
SCALE: NTS

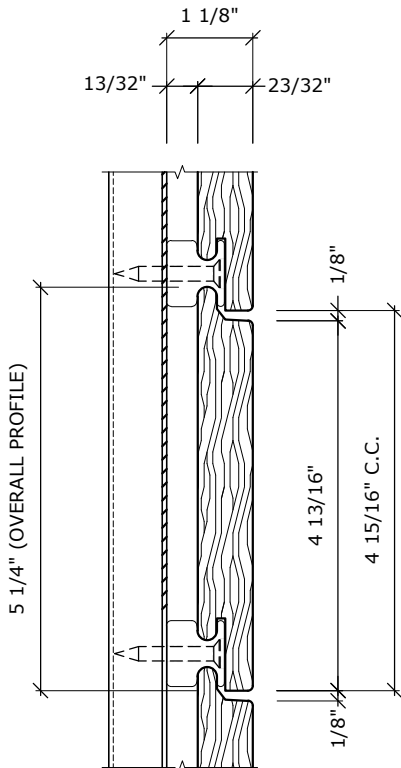

**B** TFP CLAD CLIP MAXI w/ 1" X 6" 1/8 REVEAL RAINSCREEN  
SCALE: NTS

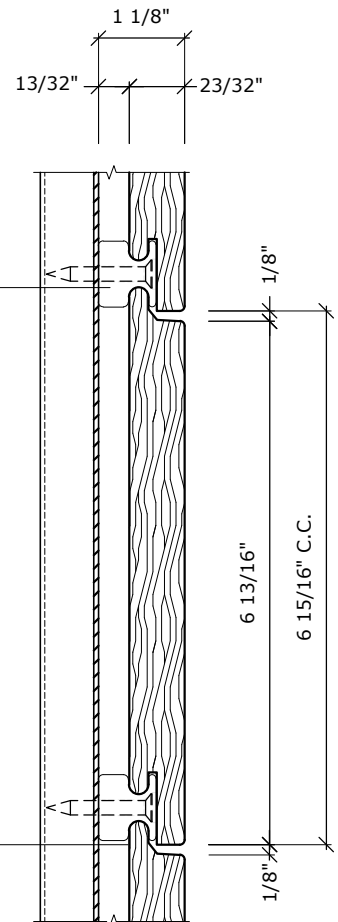

**C** TFP CLAD CLIP MAXI w/ 1" X 8" 1/8 REVEAL RAINSCREEN  
SCALE: NTS

THESE GUIDE DETAILS ARE PROVIDED FOR INFORMATION ONLY AND OUTLINE GENERAL/TYPICAL REQUIREMENTS FOR THE ATTACHMENT SYSTEM. PROJECT SPECIFIC ENGINEERING WILL ADDRESS STRUCTURAL ATTACHMENT (I.E. FASTENING PATTERN, ETC.). CONTACT KWS FOR FURTHER DETAILS. ALL IMPLIED WARRANTIES INCLUDING MERCHANTABILITY & FITNESS FOR A PARTICULAR PURPOSE ARE EXPRESSLY EXCLUDED.

TROPICAL FOREST PRODUCTS COPYRIGHT 2021

# TROPICAL

## LAYUP DIMENSIONS - 1" WITH 1/4" REVEAL SCALE: NTS

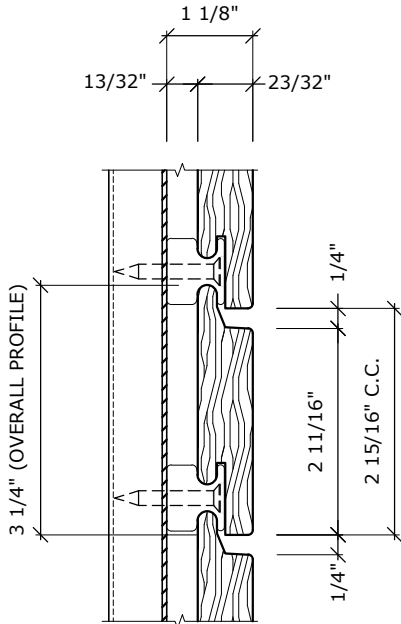

**A** TFP CLAD CLIP MAXI w/ 1" X 4" 1/4 REVEAL RAINSCREEN  
SCALE: NTS

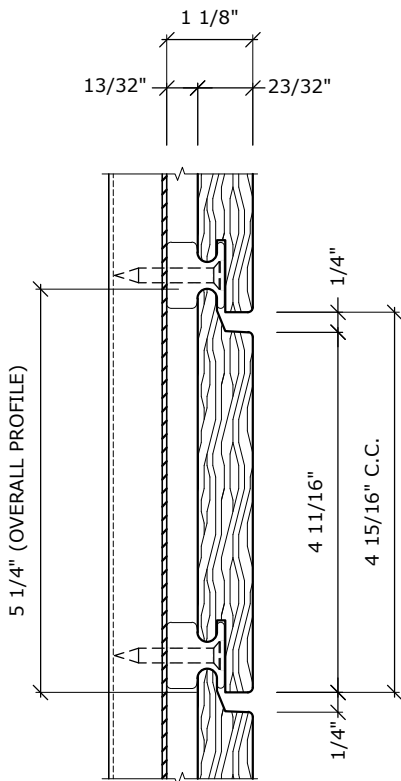

**B** TFP CLAD CLIP MAXI w/ 1" X 6" 1/4 REVEAL RAINSCREEN  
SCALE: NTS

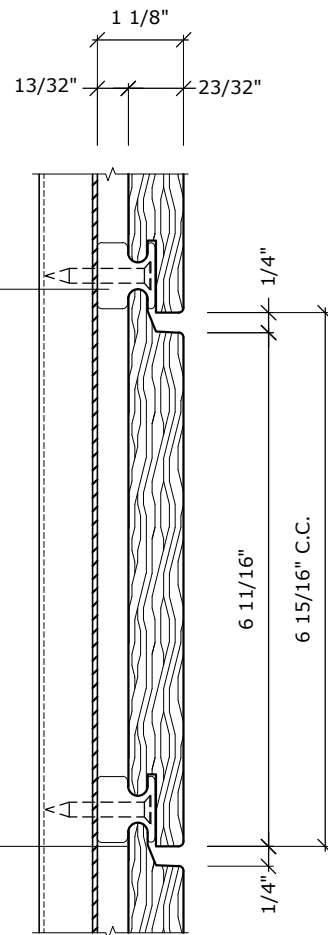

**C** TFP CLAD CLIP MAXI w/ 1" X 8" 1/4 REVEAL RAINSCREEN  
SCALE: NTS

THESE GUIDE DETAILS ARE PROVIDED FOR INFORMATION ONLY AND OUTLINE GENERAL/TYPICAL REQUIREMENTS FOR THE ATTACHMENT SYSTEM. PROJECT SPECIFIC ENGINEERING WILL ADDRESS STRUCTURAL ATTACHMENT (I.E. FASTENING PATTERN, ETC.). CONTACT KWS FOR FURTHER DETAILS. ALL IMPLIED WARRANTIES INCLUDING MERCHANTABILITY & FITNESS FOR A PARTICULAR PURPOSE ARE EXPRESSLY EXCLUDED.

TROPICAL FOREST PRODUCTS COPYRIGHT 2021





# TROPICAL

## LAYUP DIMENSIONS - 1" WITH 1/2" REVEAL SCALE: NTS

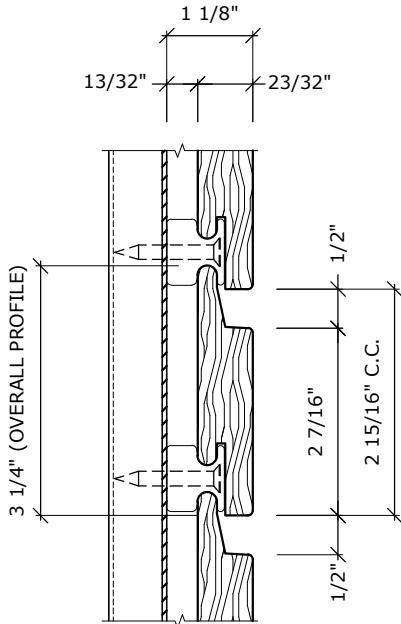

**A** TFP CLAD CLIP MAXI w/ 1" X 4" 1/2 REVEAL RAINSCREEN  
SCALE: NTS

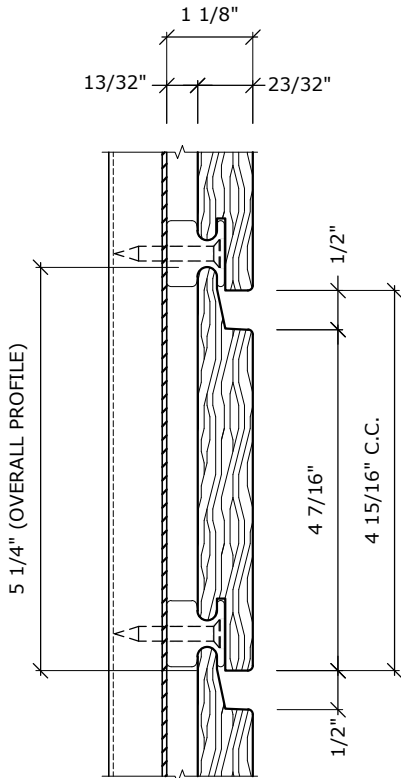

**B** TFP CLAD CLIP MAXI w/ 1" X 6" 1/2 REVEAL RAINSCREEN  
SCALE: NTS

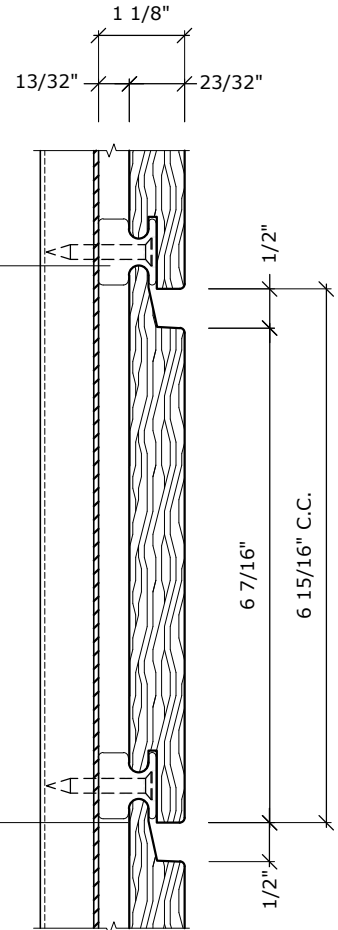

**C** TFP CLAD CLIP MAXI w/ 1" X 8" 1/2 REVEAL RAINSCREEN  
SCALE: NTS

THESE GUIDE DETAILS ARE PROVIDED FOR INFORMATION ONLY AND OUTLINE GENERAL/TYPICAL REQUIREMENTS FOR THE ATTACHMENT SYSTEM. PROJECT SPECIFIC ENGINEERING WILL ADDRESS STRUCTURAL ATTACHMENT (I.E. FASTENING PATTERN, ETC.). CONTACT KWS FOR FURTHER DETAILS. ALL IMPLIED WARRANTIES INCLUDING MERCHANTABILITY & FITNESS FOR A PARTICULAR PURPOSE ARE EXPRESSLY EXCLUDED.

TROPICAL FOREST PRODUCTS COPYRIGHT 2021

# TROPICAL

## LAYUP DIMENSIONS - 5/4" WITH NO REVEAL SCALE: NTS

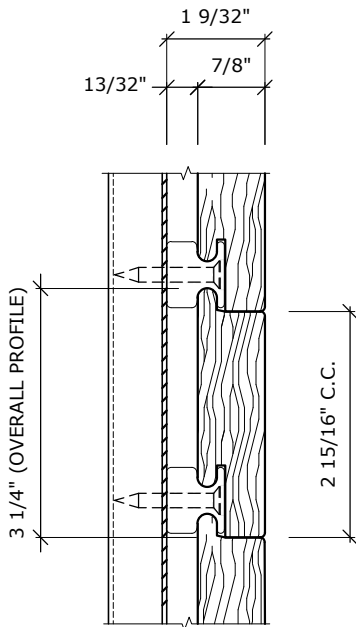

**A** TFP CLAD CLIP MAXI w/ 5/4" X 4" 1/4 NO REVEAL RAINSCREEN  
SCALE: NTS

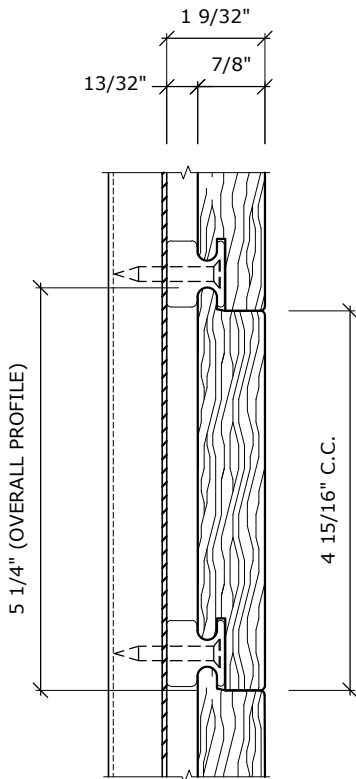

**B** TFP CLAD CLIP MAXI w/ 5/4" X 6" 1/4 NO REVEAL RAINSCREEN  
SCALE: NTS

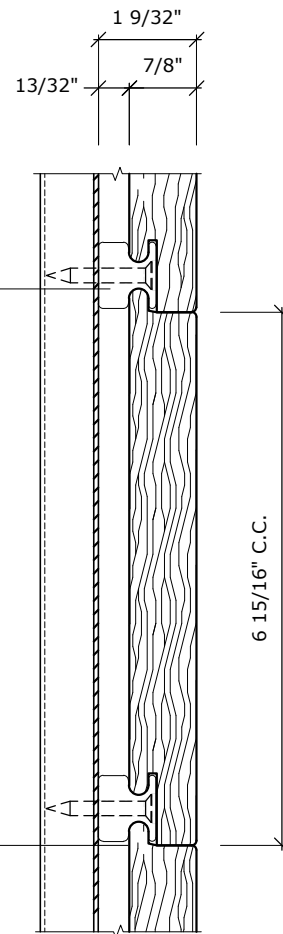

**C** TFP CLAD CLIP MAXI w/ 5/4" X 8" 1/4 NO REVEAL RAINSCREEN  
SCALE: NTS

THESE GUIDE DETAILS ARE PROVIDED FOR INFORMATION ONLY AND OUTLINE GENERAL/TYPICAL REQUIREMENTS FOR THE ATTACHMENT SYSTEM. PROJECT SPECIFIC ENGINEERING WILL ADDRESS STRUCTURAL ATTACHMENT (I.E. FASTENING PATTERN, ETC.). CONTACT KWS FOR FURTHER DETAILS. ALL IMPLIED WARRANTIES INCLUDING MERCHANTABILITY & FITNESS FOR A PARTICULAR PURPOSE ARE EXPRESSLY EXCLUDED.

TROPICAL FOREST PRODUCTS COPYRIGHT 2021



# TROPICAL

## LAYUP DIMENSIONS - 5/4" WITH 1/8" REVEAL SCALE: NTS

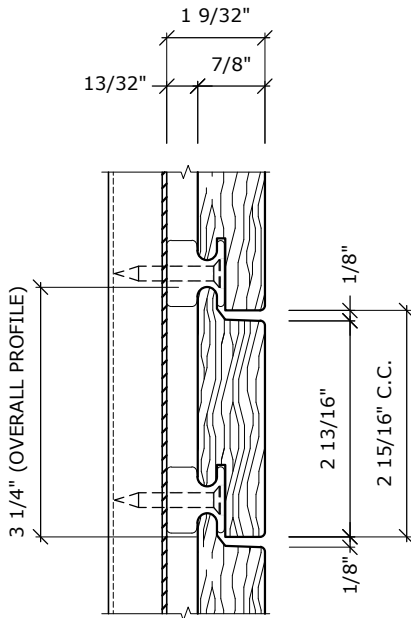

**A** TFP CLAD CLIP MAXI w/ 5/4" X 4" 1/8 REVEAL RAINSCREEN  
SCALE: NTS

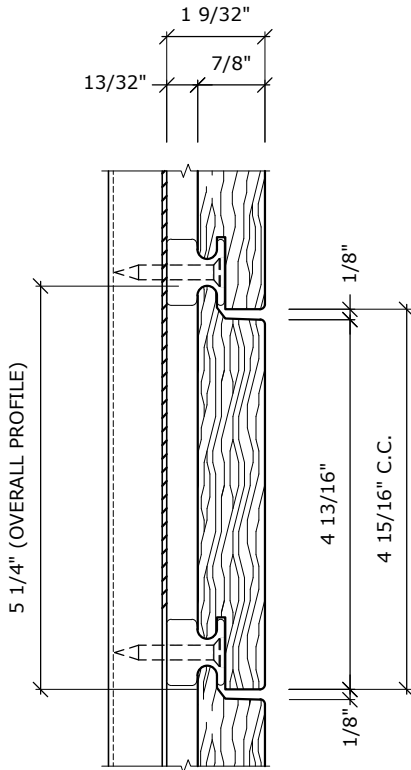

**B** TFP CLAD CLIP MAXI w/ 5/4" X 6" 1/8 REVEAL RAINSCREEN  
SCALE: NTS

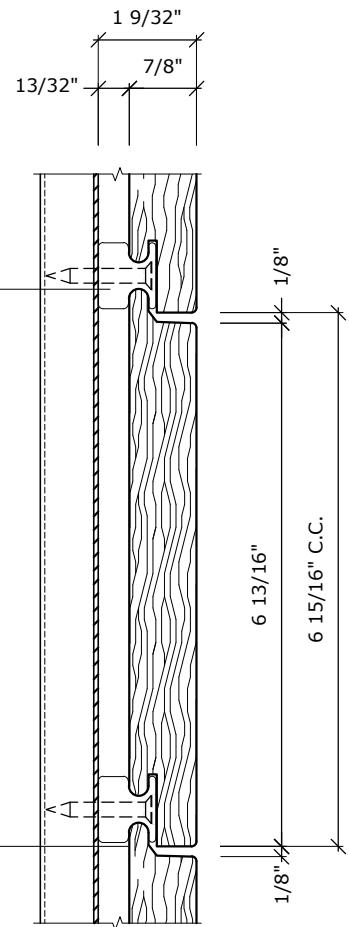

**C** TFP CLAD CLIP MAXI w/ 5/4" X 8" 1/8 REVEAL RAINSCREEN  
SCALE: NTS

THESE GUIDE DETAILS ARE PROVIDED FOR INFORMATION ONLY AND OUTLINE GENERAL/TYPICAL REQUIREMENTS FOR THE ATTACHMENT SYSTEM. PROJECT SPECIFIC ENGINEERING WILL ADDRESS STRUCTURAL ATTACHMENT (I.E. FASTENING PATTERN, ETC.). CONTACT KWS FOR FURTHER DETAILS. ALL IMPLIED WARRANTIES INCLUDING MERCHANTABILITY & FITNESS FOR A PARTICULAR PURPOSE ARE EXPRESSLY EXCLUDED.

TROPICAL FOREST PRODUCTS COPYRIGHT 2021

# TROPICAL

## LAYUP DIMENSIONS - 5/4" WITH 1/4" REVEAL SCALE: NTS

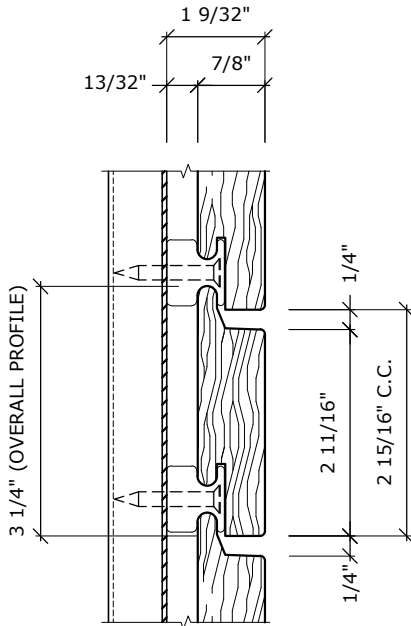

**A** TFP CLAD CLIP MAXI w/ 5/4" X 4" 1/4 REVEAL RAINSCREEN  
SCALE: NTS

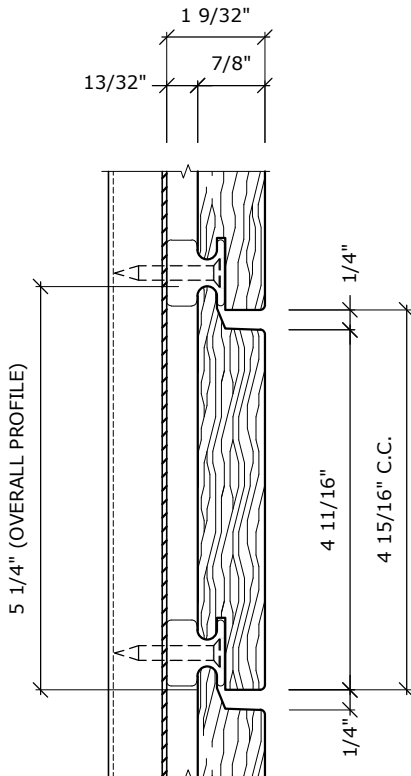

**B** TFP CLAD CLIP MAXI w/ 5/4" X 6" 1/4 REVEAL RAINSCREEN  
SCALE: NTS

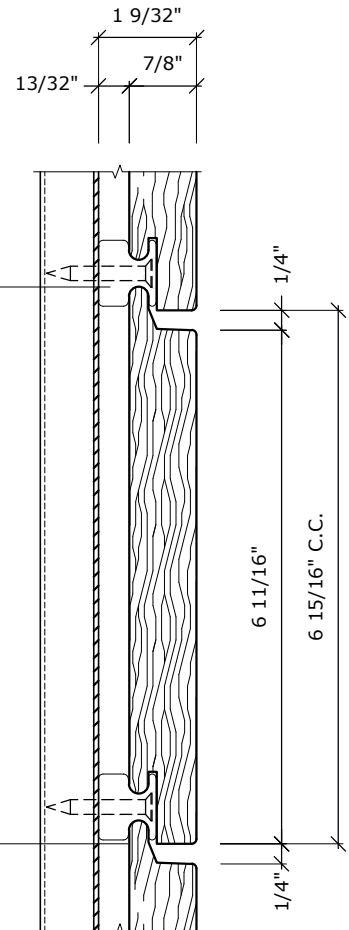

**C** TFP CLAD CLIP MAXI w/ 5/4" X 8" 1/4 REVEAL RAINSCREEN  
SCALE: NTS

THESE GUIDE DETAILS ARE PROVIDED FOR INFORMATION ONLY AND OUTLINE GENERAL/TYPICAL REQUIREMENTS FOR THE ATTACHMENT SYSTEM. PROJECT SPECIFIC ENGINEERING WILL ADDRESS STRUCTURAL ATTACHMENT (I.E. FASTENING PATTERN, ETC.). CONTACT KWS FOR FURTHER DETAILS. ALL IMPLIED WARRANTIES INCLUDING MERCHANTABILITY & FITNESS FOR A PARTICULAR PURPOSE ARE EXPRESSLY EXCLUDED.

TROPICAL FOREST PRODUCTS COPYRIGHT 2021

# TROPICAL

## LAYUP DIMENSIONS - 5/4" WITH 1/2" REVEAL SCALE: NTS

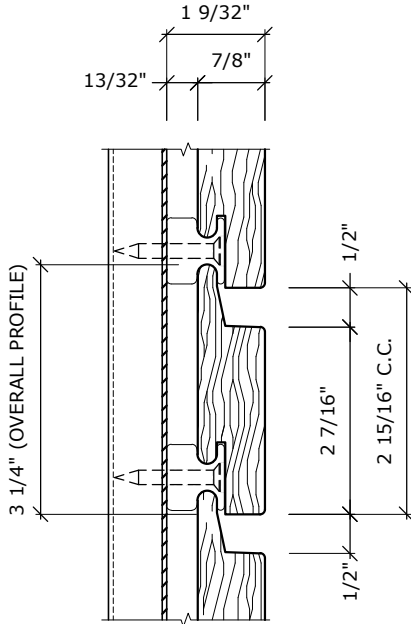

**A** TFP CLAD CLIP MAXI w/ 5/4" X 4" 1/2 REVEAL RAINSCREEN  
SCALE: NTS

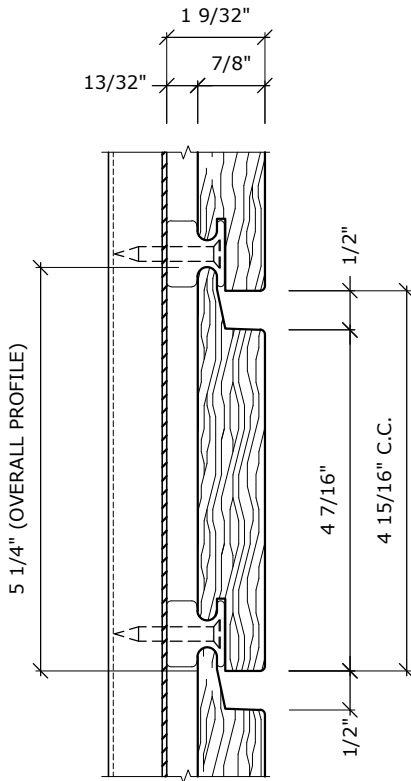

**B** TFP CLAD CLIP MAXI w/ 5/4" X 6" 1/2 REVEAL RAINSCREEN  
SCALE: NTS

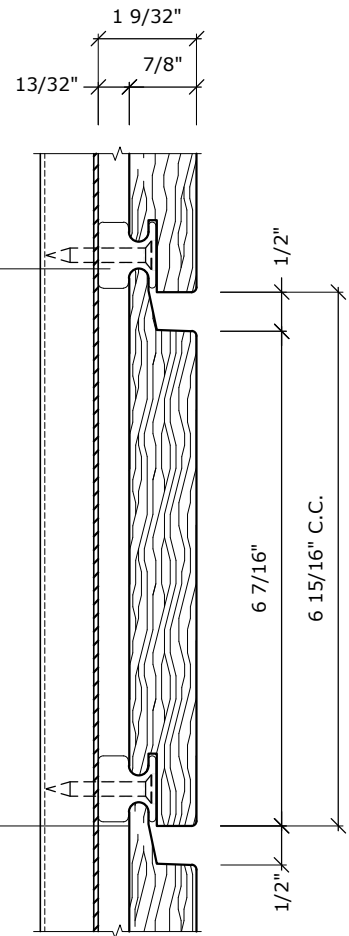

**C** TFP CLAD CLIP MAXI w/ 5/4" X 8" 1/2 REVEAL RAINSCREEN  
SCALE: NTS

THESE GUIDE DETAILS ARE PROVIDED FOR INFORMATION ONLY AND OUTLINE GENERAL/TYPICAL REQUIREMENTS FOR THE ATTACHMENT SYSTEM. PROJECT SPECIFIC ENGINEERING WILL ADDRESS STRUCTURAL ATTACHMENT (I.E. FASTENING PATTERN, ETC.). CONTACT KWS FOR FURTHER DETAILS. ALL IMPLIED WARRANTIES INCLUDING MERCHANTABILITY & FITNESS FOR A PARTICULAR PURPOSE ARE EXPRESSLY EXCLUDED.

TROPICAL FOREST PRODUCTS COPYRIGHT 2021

# TROPICAL

## TYPICAL SECTION VIEW: CI GIRT ONLY SCALE: 3"=1'-0"

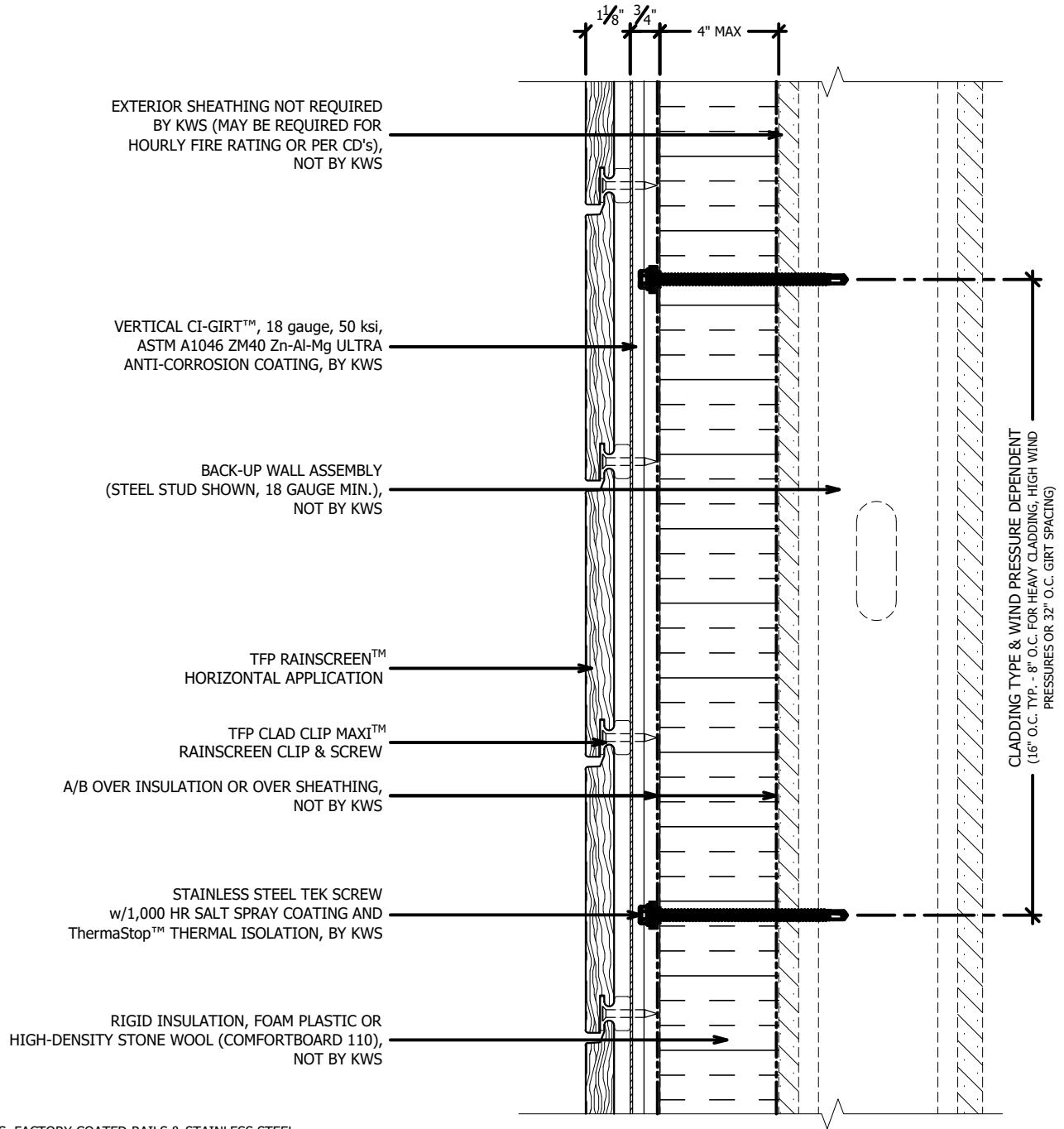

16 GAUGE RAILS, FACTORY COATED RAILS & STAINLESS STEEL (304) AVAILABLE

\*MAXIMUM ALLOWABLE SPACING AND DEAD LOAD (WEIGHT OF CLADDING) IS BASED ON THE TOTAL LOAD (DEAD + LIVE) ACTING ON THE ASSEMBLY, BRACKETS AND CONNECTIONS

SYSTEM MAY BE INSTALLED OVER STEEL STUDS, WOOD STUDS, CMU OR CONCRETE SUBSTRATES (WITH USE OF APPROPRIATE WALL ANCHORS).

THESE GUIDE DETAILS ARE PROVIDED FOR INFORMATION ONLY AND OUTLINE GENERAL/TYPICAL REQUIREMENTS FOR THE ATTACHMENT SYSTEM. PROJECT SPECIFIC ENGINEERING WILL ADDRESS STRUCTURAL ATTACHMENT (I.E. FASTENING PATTERN, ETC.). CONTACT KWS FOR FURTHER DETAILS. ALL IMPLIED WARRANTIES INCLUDING MERCHANTABILITY & FITNESS FOR A PARTICULAR PURPOSE ARE EXPRESSLY EXCLUDED.

# TROPICAL

## TYPICAL PLAN VIEW: CI GIRT ONLY SCALE: 3"=1'-0"

SYSTEM MAY BE INSTALLED OVER STEEL STUDS, WOOD STUDS, CMU OR CONCRETE SUBSTRATES (WITH USE OF APPROPRIATE WALL ANCHORS).

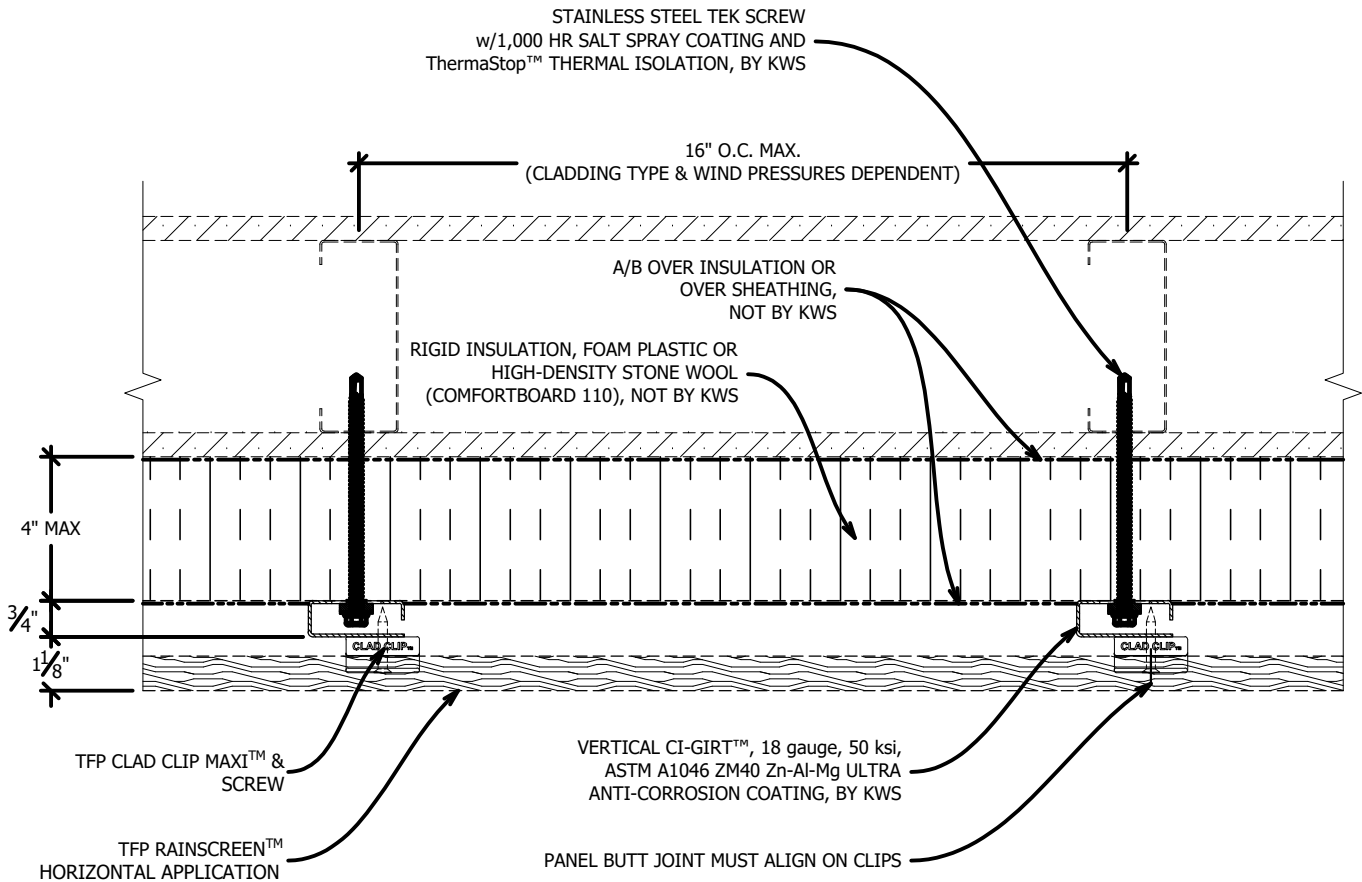

16 GAUGE RAILS, FACTORY COATED RAILS & STAINLESS STEEL  
(304) AVAILABLE

\*MAXIMUM ALLOWABLE SPACING AND DEAD LOAD (WEIGHT  
OF CLADDING) IS BASED ON THE TOTAL LOAD (DEAD + LIVE)  
ACTING ON THE ASSEMBLY, BRACKETS AND CONNECTIONS

THESE GUIDE DETAILS ARE PROVIDED FOR INFORMATION ONLY AND OUTLINE GENERAL/TYPICAL REQUIREMENTS FOR THE ATTACHMENT SYSTEM. PROJECT SPECIFIC ENGINEERING WILL ADDRESS STRUCTURAL ATTACHMENT (i.e. FASTENING PATTERN, ETC.). CONTACT KWS FOR FURTHER DETAILS. ALL IMPLIED WARRANTIES INCLUDING MERCHANTABILITY & FITNESS FOR A PARTICULAR PURPOSE ARE EXPRESSLY EXCLUDED.

# TROPICAL

## TYPICAL SECTION VIEW: CI GIRT 150 ONLY SCALE: 3"=1'-0"

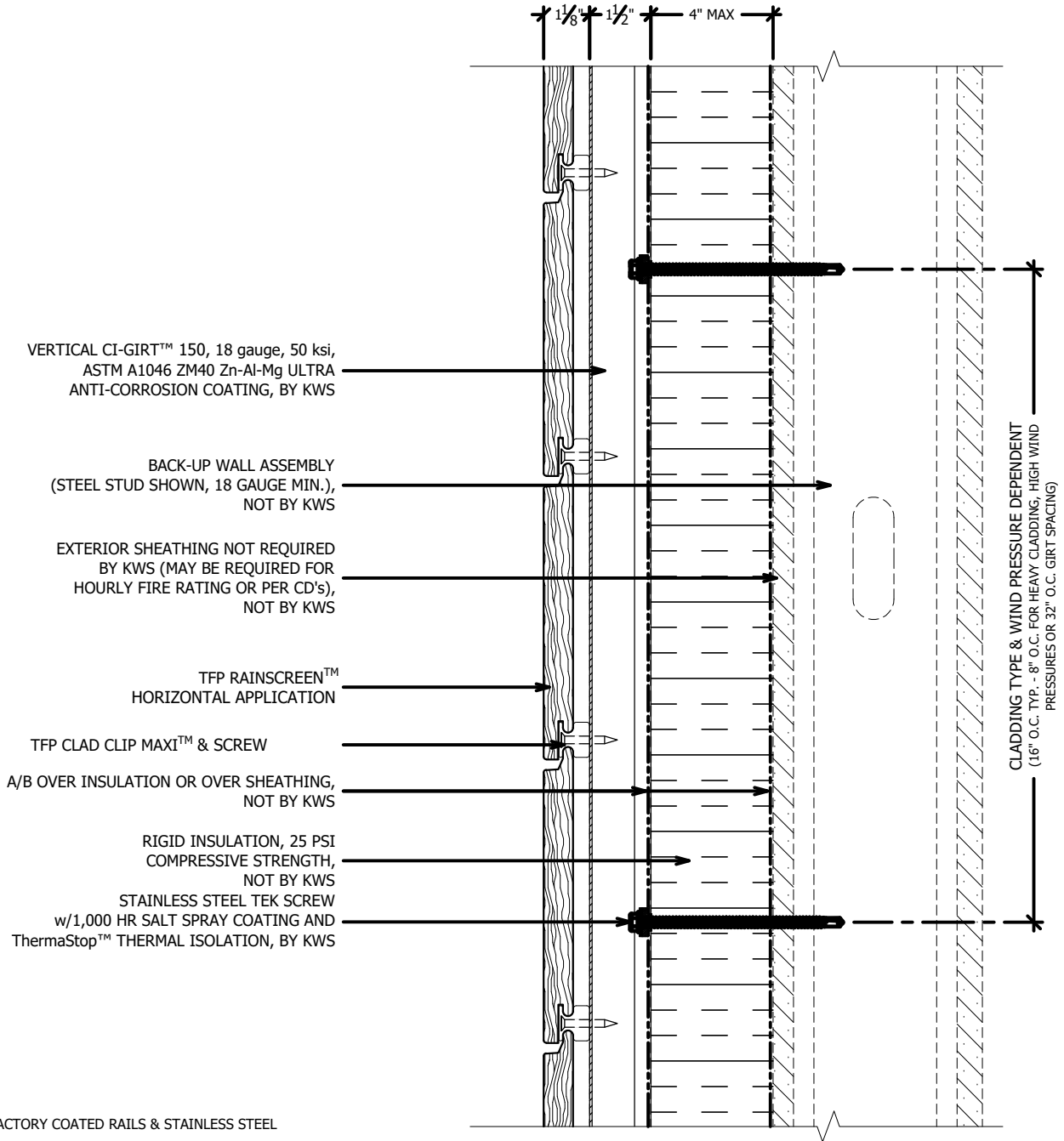

16 GAUGE RAILS, FACTORY COATED RAILS & STAINLESS STEEL (304) AVAILABLE

\*MAXIMUM ALLOWABLE SPACING AND DEAD LOAD (WEIGHT OF CLADDING) IS BASED ON THE TOTAL LOAD (DEAD + LIVE) ACTING ON THE ASSEMBLY, BRACKETS AND CONNECTIONS

SYSTEM MAY BE INSTALLED OVER STEEL STUDS, WOOD STUDS, CMU OR CONCRETE SUBSTRATES (WITH USE OF APPROPRIATE WALL ANCHORS).

THESE GUIDE DETAILS ARE PROVIDED FOR INFORMATION ONLY AND OUTLINE GENERAL/TYPICAL REQUIREMENTS FOR THE ATTACHMENT SYSTEM. PROJECT SPECIFIC ENGINEERING WILL ADDRESS STRUCTURAL ATTACHMENT (I.E. FASTENING PATTERN, ETC.). CONTACT KWS FOR FURTHER DETAILS. ALL IMPLIED WARRANTIES INCLUDING MERCHANTABILITY & FITNESS FOR A PARTICULAR PURPOSE ARE EXPRESSLY EXCLUDED.



# TROPICAL

## TYPICAL PLAN VIEW: CI GIRT 150 ONLY SCALE: 3"=1'-0"

SYSTEM MAY BE INSTALLED OVER STEEL STUDS, WOOD STUDS, CMU OR CONCRETE SUBSTRATES (WITH USE OF APPROPRIATE WALL ANCHORS).

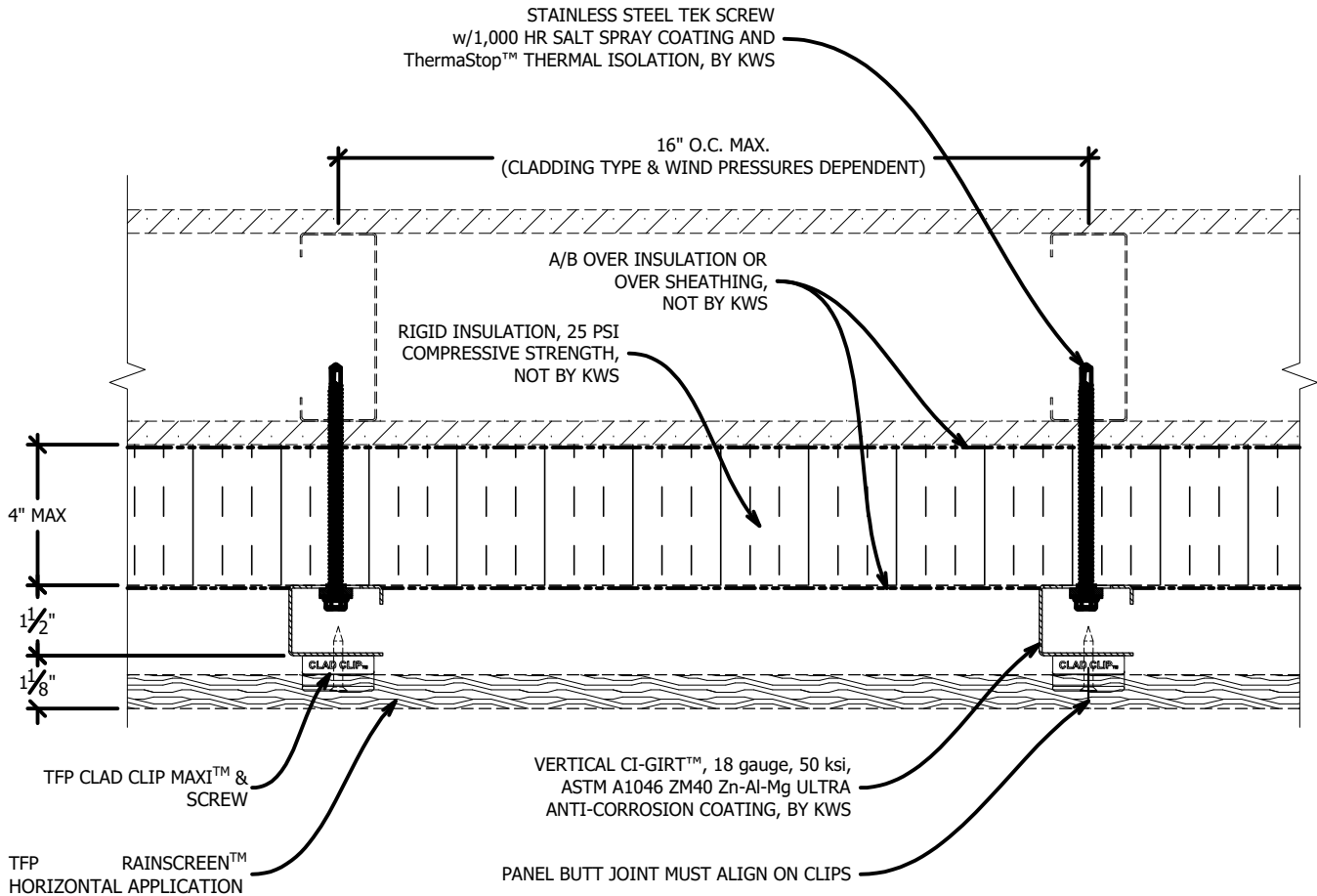

16 GAUGE RAILS, FACTORY COATED RAILS & STAINLESS STEEL  
(304) AVAILABLE

\*MAXIMUM ALLOWABLE SPACING AND DEAD LOAD (WEIGHT  
OF CLADDING) IS BASED ON THE TOTAL LOAD (DEAD + LIVE)  
ACTING ON THE ASSEMBLY, BRACKETS AND CONNECTIONS

THESE GUIDE DETAILS ARE PROVIDED FOR INFORMATION ONLY AND OUTLINE GENERAL/TYPICAL REQUIREMENTS FOR THE ATTACHMENT SYSTEM. PROJECT SPECIFIC ENGINEERING WILL ADDRESS STRUCTURAL ATTACHMENT (I.E. FASTENING PATTERN, ETC.). CONTACT KWS FOR FURTHER DETAILS. ALL IMPLIED WARRANTIES INCLUDING MERCHANTABILITY & FITNESS FOR A PARTICULAR PURPOSE ARE EXPRESSLY EXCLUDED.

# TROPICAL

## TYPICAL OUTSIDE CORNER CONDITION SCALE: 3"=1'-0"

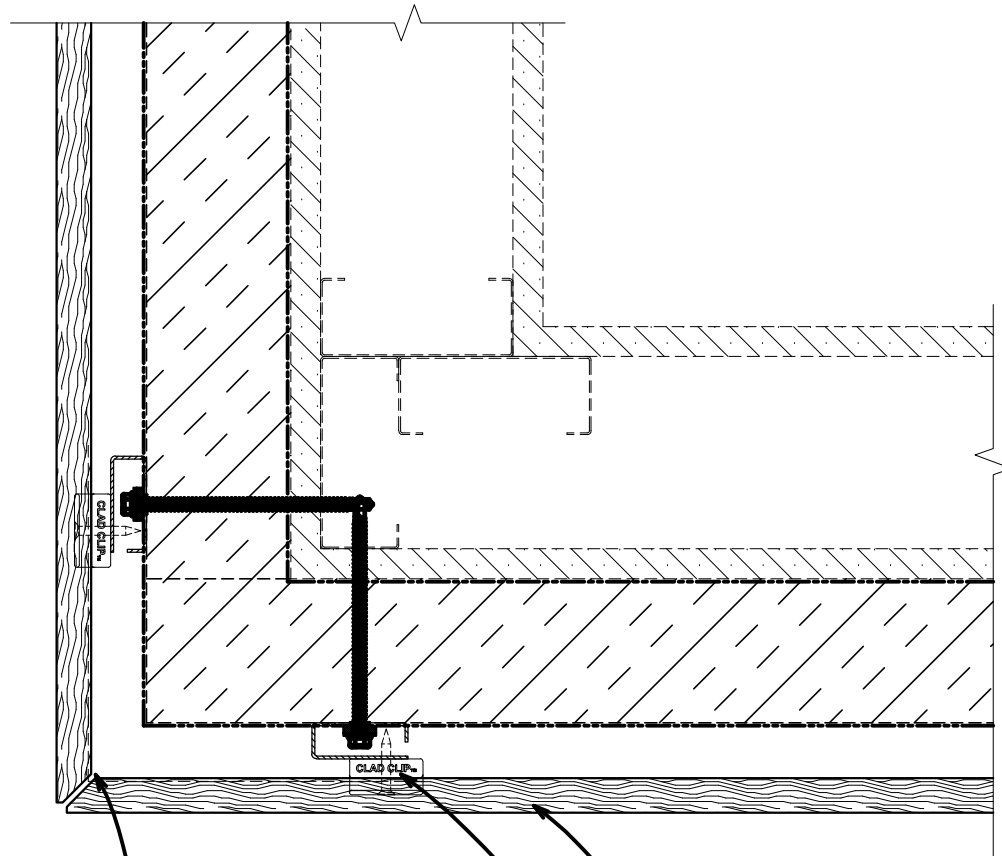

BACKING ('L') MAY BE REQUIRED AT OUTSIDE CORNER. CONSULT CLADDING MANUFACTURER FOR DETAILS & REQUIREMENTS. THIS IS NOT REQUIRED OR SUPPLIED BY KWS.

TFP RAINSCREEN™  
HORIZONTAL APPLICATION  
TFP CLAD CLIP MAXI™ & SCREW

16 GAUGE RAILS, FACTORY COATED RAILS & STAINLESS STEEL (304) AVAILABLE

\*MAXIMUM ALLOWABLE SPACING AND DEAD LOAD (WEIGHT OF CLADDING) IS BASED ON THE TOTAL LOAD (DEAD + LIVE) ACTING ON THE ASSEMBLY, BRACKETS AND CONNECTIONS

THESE GUIDE DETAILS ARE PROVIDED FOR INFORMATION ONLY AND OUTLINE GENERAL/TYPICAL REQUIREMENTS FOR THE ATTACHMENT SYSTEM. PROJECT SPECIFIC ENGINEERING WILL ADDRESS STRUCTURAL ATTACHMENT (i.e. FASTENING PATTERN, ETC.). CONTACT KWS FOR FURTHER DETAILS. ALL IMPLIED WARRANTIES INCLUDING MERCHANTABILITY & FITNESS FOR A PARTICULAR PURPOSE ARE EXPRESSLY EXCLUDED.

# TROPICAL

## TYPICAL INSIDE CORNER CONDITION SCALE: 3"=1'-0"

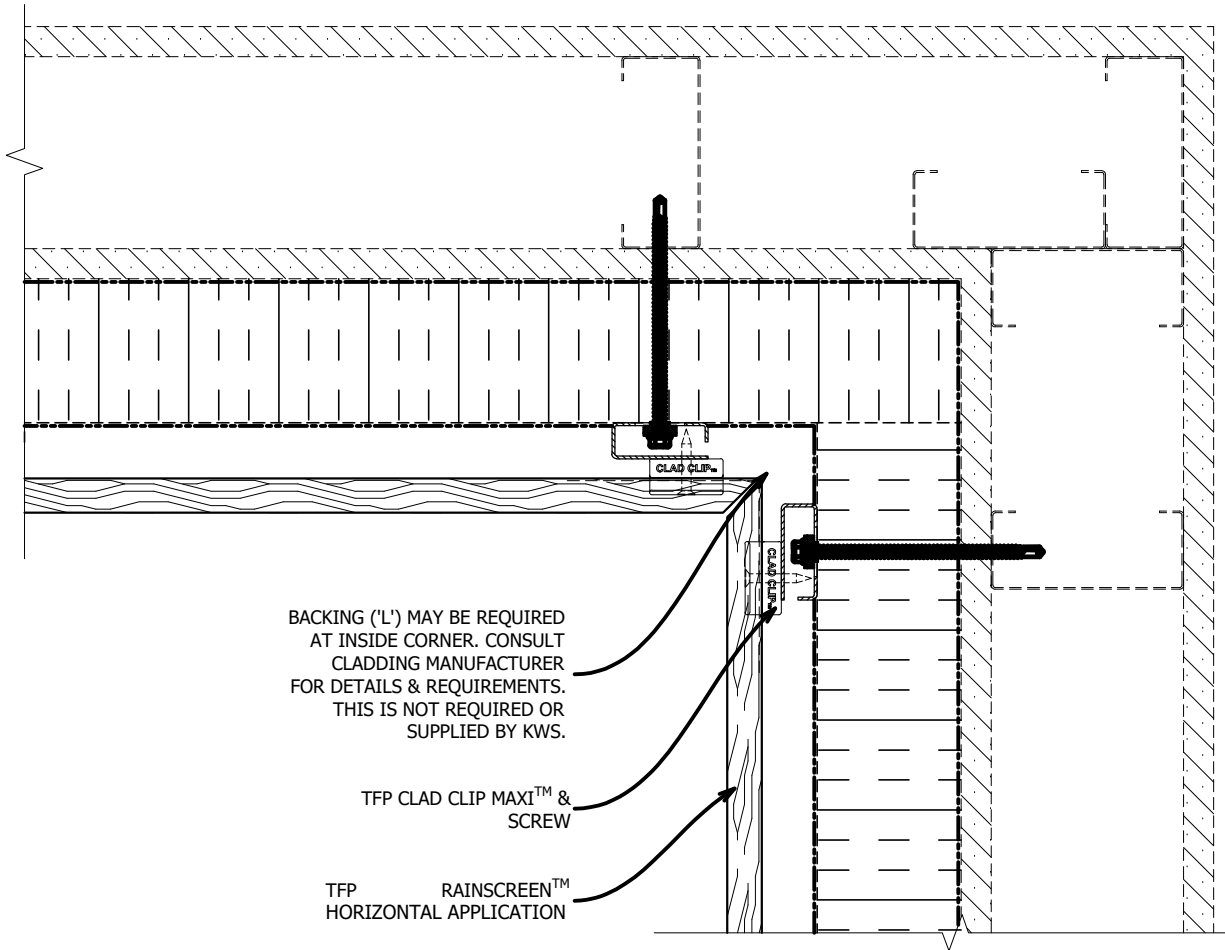

TROPICAL FOREST PRODUCTS COPYRIGHT 2021

16 GAUGE RAILS, FACTORY COATED RAILS & STAINLESS STEEL (304) AVAILABLE

\*MAXIMUM ALLOWABLE SPACING AND DEAD LOAD (WEIGHT OF CLADDING) IS BASED ON THE TOTAL LOAD (DEAD + LIVE) ACTING ON THE ASSEMBLY, BRACKETS AND CONNECTIONS

THESE GUIDE DETAILS ARE PROVIDED FOR INFORMATION ONLY AND OUTLINE GENERAL/TYPICAL REQUIREMENTS FOR THE ATTACHMENT SYSTEM. PROJECT SPECIFIC ENGINEERING WILL ADDRESS STRUCTURAL ATTACHMENT (i.e. FASTENING PATTERN, ETC.). CONTACT KWS FOR FURTHER DETAILS. ALL IMPLIED WARRANTIES INCLUDING MERCHANTABILITY & FITNESS FOR A PARTICULAR PURPOSE ARE EXPRESSLY EXCLUDED.

# TROPICAL

## TYPICAL JAMB CONDITION SCALE: 3"=1'-0"

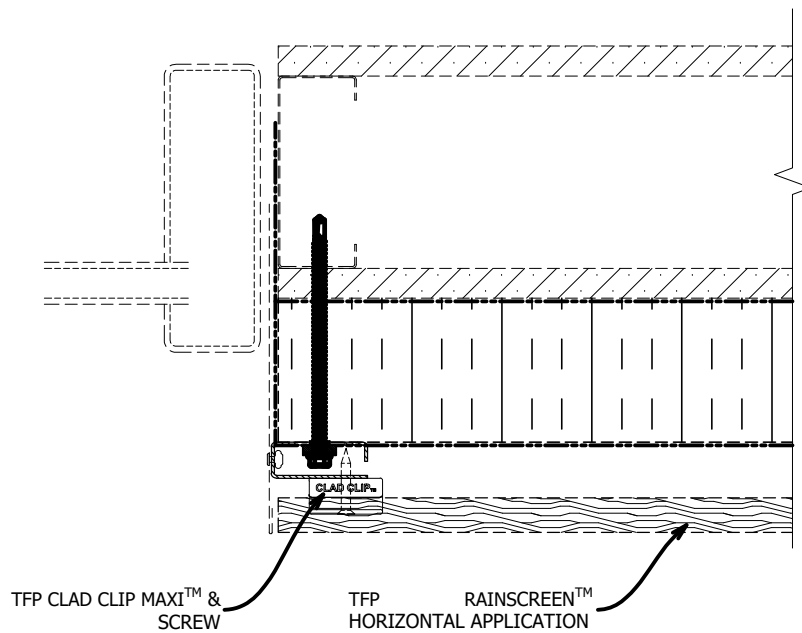

ENSURE THE FULL WIDTH OF THE CI-Girt RESTS ON INSULATION. DO NOT ALLOW CI-Girt TO OVERHANG INSULATION.

\* FLASHING DETAILS VARY BASED ON WINDOW TYPE, POSITION (INSET VS FLUSH) AND CLADDING TYPE. FLASHING IS NOT BY KWS.

16 GAUGE RAILS, FACTORY COATED RAILS & STAINLESS STEEL (304) AVAILABLE

\*MAXIMUM ALLOWABLE SPACING AND DEAD LOAD (WEIGHT OF CLADDING) IS BASED ON THE TOTAL LOAD (DEAD + LIVE) ACTING ON THE ASSEMBLY, BRACKETS AND CONNECTIONS

THESE GUIDE DETAILS ARE PROVIDED FOR INFORMATION ONLY AND OUTLINE GENERAL/TYPICAL REQUIREMENTS FOR THE ATTACHMENT SYSTEM. PROJECT SPECIFIC ENGINEERING WILL ADDRESS STRUCTURAL ATTACHMENT (i.e. FASTENING PATTERN, ETC.). CONTACT KWS FOR FURTHER DETAILS. ALL IMPLIED WARRANTIES INCLUDING MERCHANTABILITY & FITNESS FOR A PARTICULAR PURPOSE ARE EXPRESSLY EXCLUDED.

# TROPICAL

## TYPICAL HEAD & SILL CONDITION SCALE: 3"=1'-0"

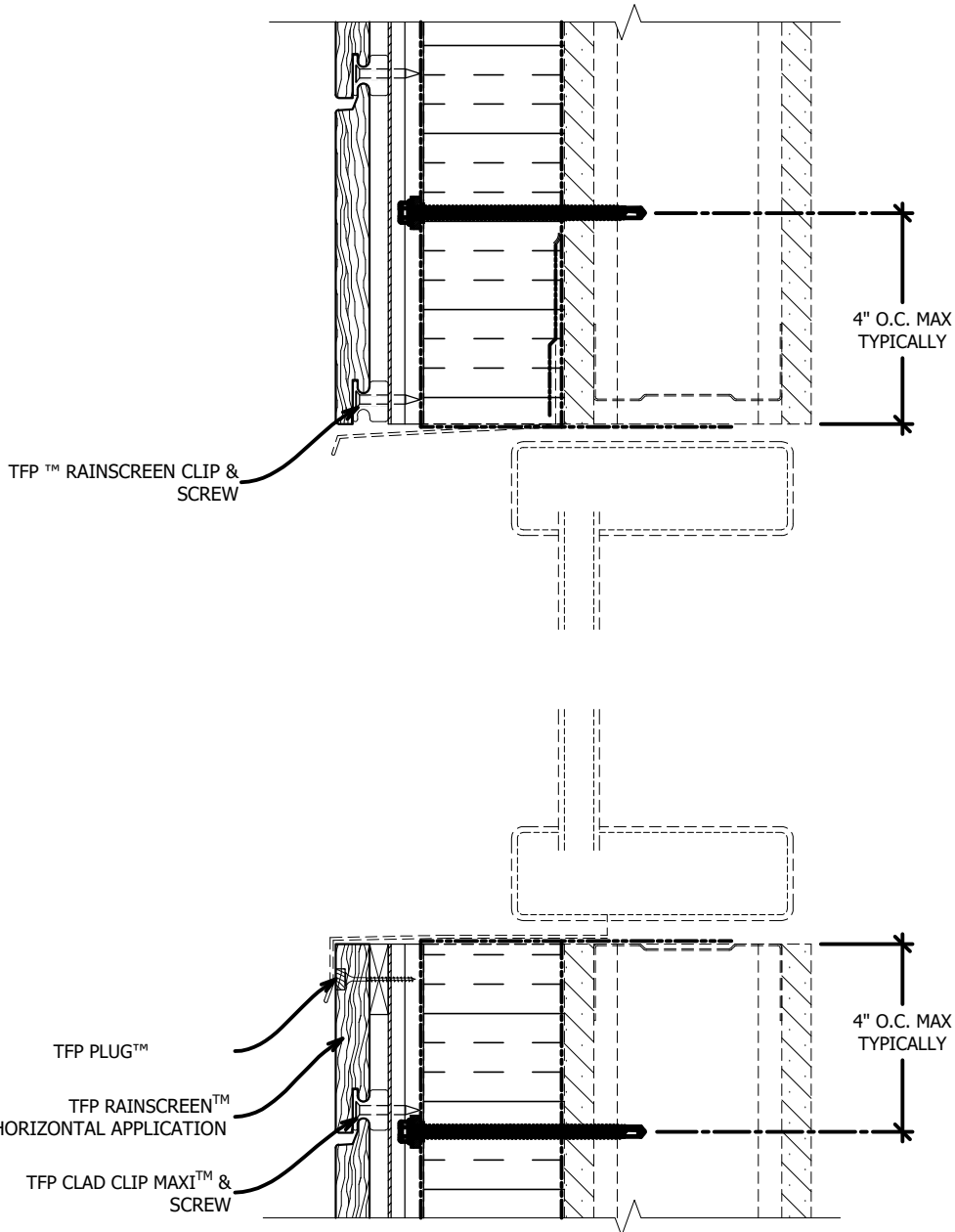

ENSURE THE CI-Girt DOES NOT EXTEND/CANTILEVER PAST INSULATION.

16 GAUGE RAILS, FACTORY COATED RAILS & STAINLESS STEEL (304) AVAILABLE

\*MAXIMUM ALLOWABLE SPACING AND DEAD LOAD (WEIGHT OF CLADDING) IS BASED ON THE TOTAL LOAD (DEAD + LIVE) ACTING ON THE ASSEMBLY, BRACKETS AND CONNECTIONS

\* FLASHING DETAILS VARY BASED ON WINDOW TYPE, POSITION (INSET VS FLUSH) AND CLADDING TYPE. FLASHING IS NOT BY KWS.

THESE GUIDE DETAILS ARE PROVIDED FOR INFORMATION ONLY AND OUTLINE GENERAL/TYPICAL REQUIREMENTS FOR THE ATTACHMENT SYSTEM. PROJECT SPECIFIC ENGINEERING WILL ADDRESS STRUCTURAL ATTACHMENT (i.e. FASTENING PATTERN, ETC.). CONTACT KWS FOR FURTHER DETAILS. ALL IMPLIED WARRANTIES INCLUDING MERCHANTABILITY & FITNESS FOR A PARTICULAR PURPOSE ARE EXPRESSLY EXCLUDED.

## TYPICAL BASE OF WALL CONDITION SCALE: 3"=1'-0"

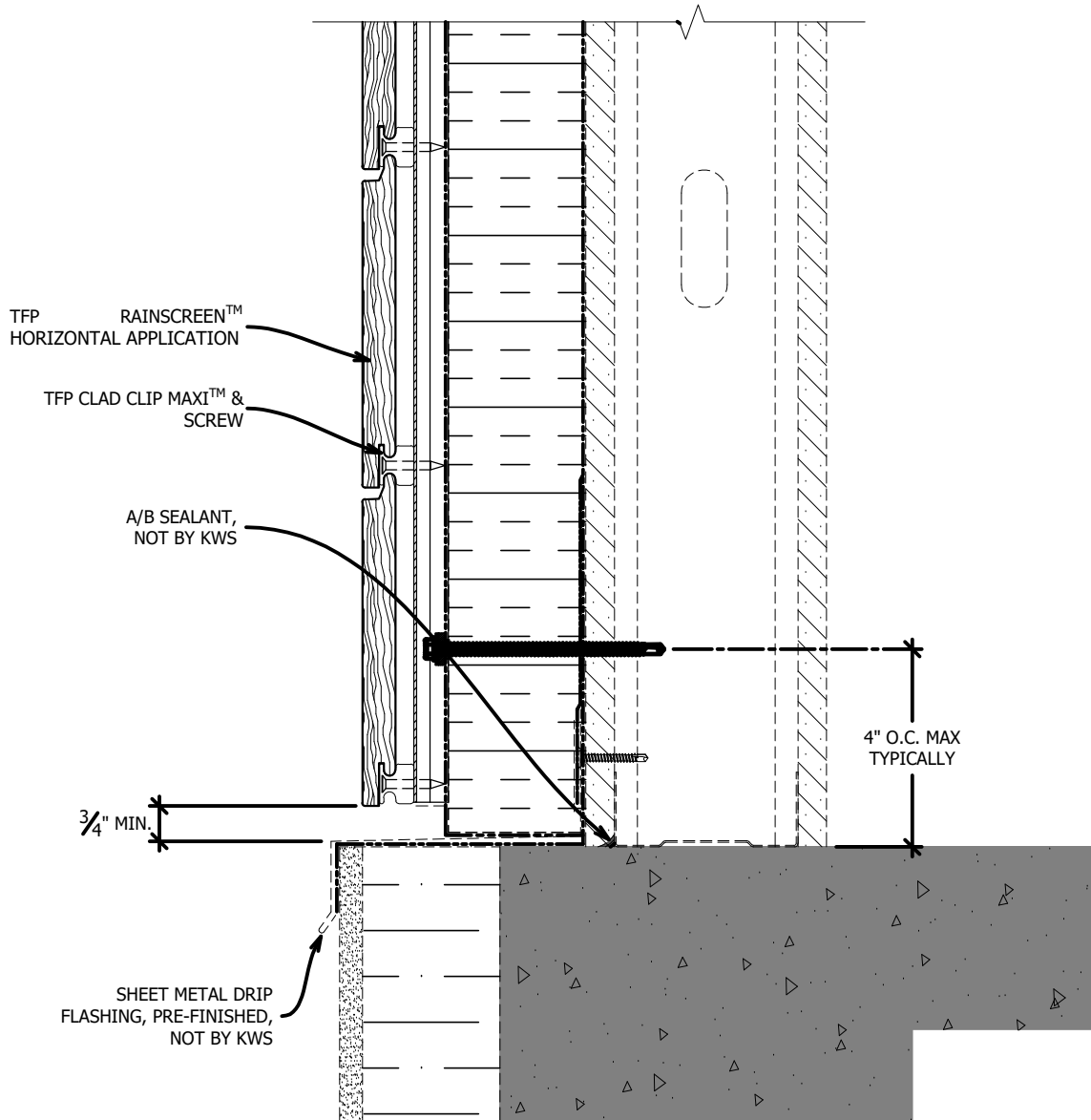

\* CLEAR & UNRESTRICTED VENTILATION & DRAINAGE  
 REQUIRED AT BASE OF WALL

16 GAUGE RAILS, FACTORY COATED RAILS & STAINLESS STEEL  
 (304) AVAILABLE

\*MAXIMUM ALLOWABLE SPACING AND DEAD LOAD (WEIGHT  
 OF CLADDING) IS BASED ON THE TOTAL LOAD (DEAD + LIVE)  
 ACTING ON THE ASSEMBLY, BRACKETS AND CONNECTIONS

THESE GUIDE DETAILS ARE PROVIDED FOR INFORMATION ONLY AND OUTLINE GENERAL/TYPICAL REQUIREMENTS FOR THE ATTACHMENT SYSTEM. PROJECT SPECIFIC ENGINEERING WILL ADDRESS STRUCTURAL ATTACHMENT (i.e. FASTENING PATTERN, ETC.). CONTACT KWS FOR FURTHER DETAILS. ALL IMPLIED WARRANTIES INCLUDING MERCHANTABILITY & FITNESS FOR A PARTICULAR PURPOSE ARE EXPRESSLY EXCLUDED.

# TROPICAL

## TYPICAL FLOOR DEFLECTION JOINT SCALE: 3"=1'-0"

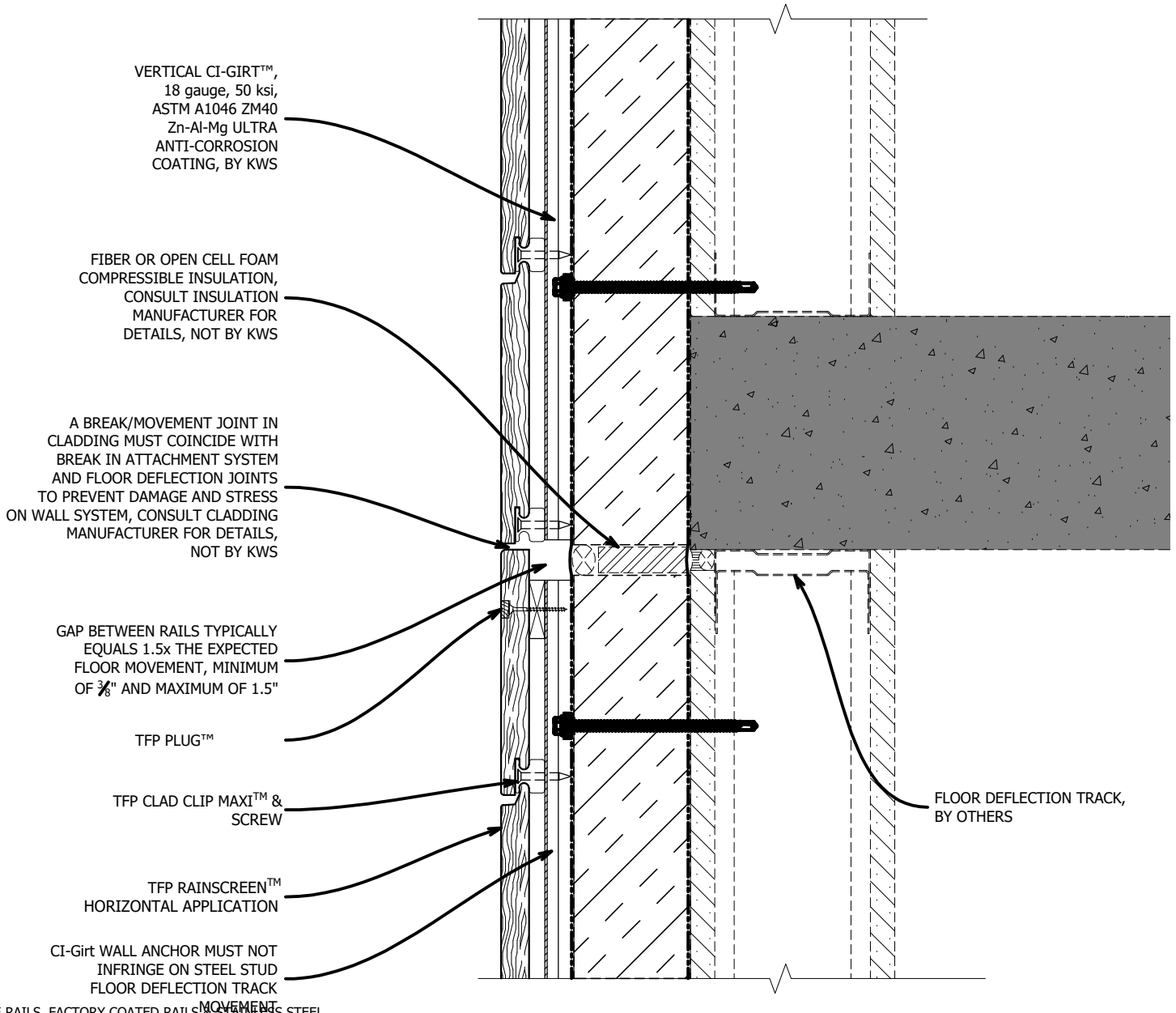

16 GAUGE RAILS, FACTORY COATED RAILS & STAINLESS STEEL (304) AVAILABLE

\*MAXIMUM ALLOWABLE SPACING AND DEAD LOAD (WEIGHT OF CLADDING) IS BASED ON THE TOTAL LOAD (DEAD + LIVE) ACTING ON THE ASSEMBLY, BRACKETS AND CONNECTIONS

THESE GUIDE DETAILS ARE PROVIDED FOR INFORMATION ONLY AND OUTLINE GENERAL/TYPICAL REQUIREMENTS FOR THE ATTACHMENT SYSTEM. PROJECT SPECIFIC ENGINEERING WILL ADDRESS STRUCTURAL ATTACHMENT (i.e. FASTENING PATTERN, ETC.). CONTACT KWS FOR FURTHER DETAILS. ALL IMPLIED WARRANTIES INCLUDING MERCHANTABILITY & FITNESS FOR A PARTICULAR PURPOSE ARE EXPRESSLY EXCLUDED.

# KNIGHT WALL SYSTEMS GENERAL NOTES:

- KNIGHT WALL SYSTEMS (KWS) IS NOT RESPONSIBLE FOR INFORMATION SHOWN ON ALL DETAILS BEYOND KWS SPECIFIC SCOPE OF WORK (INDICATED AS "BY KWS").
- ALWAYS CONSULT THE PANELS INSTALLATION & DESIGN MANUAL FOR FURTHER INFORMATION AND THE LATEST REQUIREMENTS ON ANY PANEL INSTALLATION. THESE DETAILS ARE ONLY TO COMMUNICATE HOW KWS ATTACHMENT SYSTEMS CAN BE USED WITH CLADDING PANELS/SIDING, NOT NECESSARILY THE PANEL/SIDING REQUIREMENTS AS THEY VARY FROM MANUFACTURER TO MANUFACTURER.
- SYSTEM MAY BE INSTALLED OVER STEEL STUDS, WOOD STUDS, CMU OR CONCRETE SUBSTRATES (WITH USE OF APPROPRIATE WALL ANCHORS).
- PROJECT SPECIFIC ENGINEERING CAN BE PROVIDED BY KWS AND IS REQUIRED FOR A 10 YEAR LIMITED WRITTEN WARRANTY. KWS PROJECT SPECIFIC ENGINEERING, IF SUPPLIED, IS LIMITED TO THE LOAD CARRYING COMPONENTS OF THE PRODUCTS AND FASTENERS SUPPLIED BY KWS. THE BACK-UP WALL, WALL CLADDING PANELS AND/OR RAILS SUPPLIED BY OTHERS ARE WITH OTHER PARTIES.
- PLEASE READ OUR INSTALLATION AND DESIGN RECOMMENDATIONS DOCUMENT FOR FURTHER INFORMATION THAT IS IMPORTANT FOR YOUR SPECIFIC PROJECT AND PROPER INSTALLATION.
- DETAILS OF ADJACENT WORK ARE SHOWN FOR COMPLETENESS, CLARITY AND CONVENIENCE AS AN EXAMPLE OF A BUILT ENVIRONMENT ONLY.
- THE STRUCTURAL SUPPORT, BACK-UP WALL AND SUPER STRUCTURE DESIGN IS WITH OTHER PARTIES (SUCH AS, BUT NOT LIMITED TO, STEEL STUD WALL, etc.). THE RESPONSIBILITY FOR THESE OTHER ASSEMBLIES TO ACCOMMODATE ALL LOADS IMPOSED UPON THEM BY KWS PRODUCTS, OR ANY ATTACHMENT OR PANEL SYSTEM, SHOULD BE CONSIDERED.
- SOFT JOINTS, SEALANT AND FLASHING SPECIFICATIONS, DESIGN AND INSTALLATION ARE WITH OTHER PARTIES.
- WEATHER RESISTANT/AIR BARRIER AND INSULATION SPECIFICATIONS, DETAILING AND INSTALLATION, INCLUDING PENETRATIONS, ARE WITH OTHER PARTIES.
- INTERACTION BETWEEN DISSIMILAR MATERIALS, SUCH AS ALUMINUM AND STEEL, MUST BE SEPARATED VIA PLASTIC SHIMS, TAPE OR COATING TO PREVENT GALVANIC REACTION.
- USE SHEARING INSTRUMENTS FOR CUTTING METAL FRAMING COMPONENTS. SAWS ARE NOT RECOMMENDED, AS THE SPARKS PRODUCED DURING CUTTING WILL DAMAGE THE ANTI-CORROSION COATING. IF SPARKS ARE GENERATED DURING CUTTING, BE SURE THE PORTION OF THE COMPONENT TO BE INSTALLED ON THE BUILDING IS PROTECTED FROM SPARKS. THE SYSTEMS COMPONENTS MUST NOT BE CUT WHILE INSTALLED ON THE BUILDING UNLESS USING A SHEARING INSTRUMENT (I.E. SNIPS, etc.).
- USE OF IMPACT DRIVERS IS NOT RECOMMENDED WHEN DRIVING ANY FASTENER FOR THE SYSTEM.
- EXTERIOR INSULATION CAN BE RIGID FOAM PLASTIC OR HIGH-DENSITY STONE WOOL (COMFORTBOARD 110).
- CI, CI-Girt, HCI, HCI-Girt, RevealRail, Reveal-Girt, PanelRail and ThermaStop are trademarks of Knight Wall Systems, inc.
- THE DETAILS WITHIN THIS DRAWING PACKAGE ARE NOT INTENDED TO REPLACE PROJECT SPECIFIC ENGINEERING CALCULATIONS OR THE DESIGN SERVICES OF A REGISTERED PROFESSIONAL DESIGNER AND ARE SUBJECT TO CHANGE AT ANY TIME.

NOTICE: No freedom from any patent owned by Knight Wall Systems or others is to be inferred. Because use conditions and applicable laws may differ from one location to another and may change with time, Customer is responsible for determining whether products and the information in this document are appropriate for Customer's use and for ensuring that Customer's workplace and disposal practices are in compliance with applicable laws and other government enactments. Knight Wall Systems assumes no obligation or liability for the information in this document. **NO EXPRESS WARRANTIES ARE GIVEN EXCEPT FOR ANY APPLICABLE WRITTEN LIMITED WARRANTIES SPECIFICALLY PROVIDED BY KNIGHT WALL SYSTEMS. ALL IMPLIED WARRANTIES INCLUDING THOSE OF MERCHANTABILITY AND FITNESS FOR A PARTICULAR PURPOSE ARE EXPRESSLY EXCLUDED.** Building and/or construction practices unrelated to building materials could greatly affect moisture and the potential for mold formation. No material supplier including Knight Wall Systems can give assurance that mold will not develop in any specific system.

10/08/2018

PLEASE FEEL FREE TO CONTACT KWS OR A LOCAL KWS REPRESENTATIVE FOR PROJECT SPECIFIC ASSISTANCE WITH DETAILS AND SPECIFYING  
1.855.KWS.WALL  
Info@knightwallsystems.com  
www.knightwallsystems.com

THESE GUIDE DETAILS ARE PROVIDED FOR INFORMATION ONLY AND OUTLINE GENERAL/TYPICAL REQUIREMENTS FOR THE ATTACHMENT SYSTEM. PROJECT SPECIFIC ENGINEERING WILL ADDRESS STRUCTURAL ATTACHMENT (i.e. FASTENING PATTERN, ETC.). CONTACT KWS FOR FURTHER DETAILS. ALL IMPLIED WARRANTIES INCLUDING MERCHANTABILITY & FITNESS FOR A PARTICULAR PURPOSE ARE EXPRESSLY EXCLUDED. Please visit us online for more information & CAD files  
www.knightwallsystems.com  
© Knight Wall Systems Deer Park, WA - 1.855.KWS.WALL  
PATENT US 8,429,866 B2, OTHERS PENDING - Drawn by: BN

## KNIGHT WALL HCI™ System (HCI-Girt ONLY) RAINSCREEN ATTACHMENT

6200 Tomken Rd Mississauga, ON - L5T 1X7 - Canada  
1-855-344-4500 | www.TropicalForestProducts.com | info@tropicalforestproducts.com  
© All Rights Reserved - Tropical Forest Products 2023



# TROPICAL

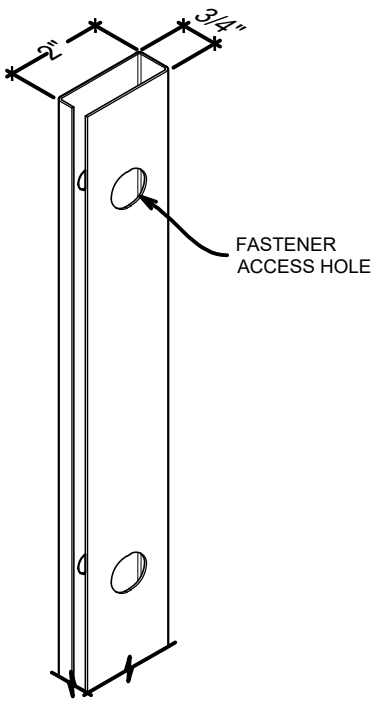

FRONT VIEW

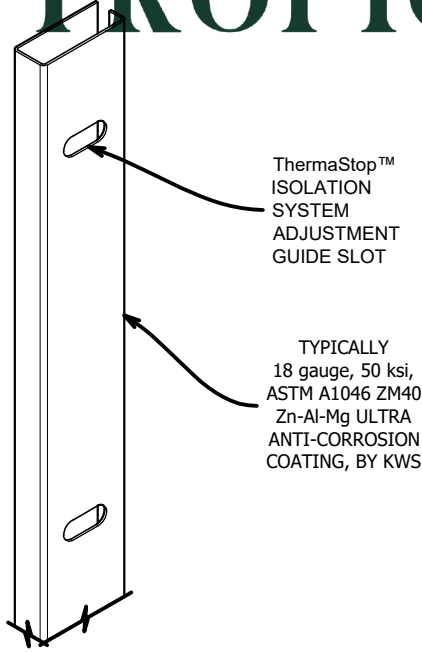

BACK VIEW

**A** CI-Girt™ (STANDARD)  
SCALE: NTS

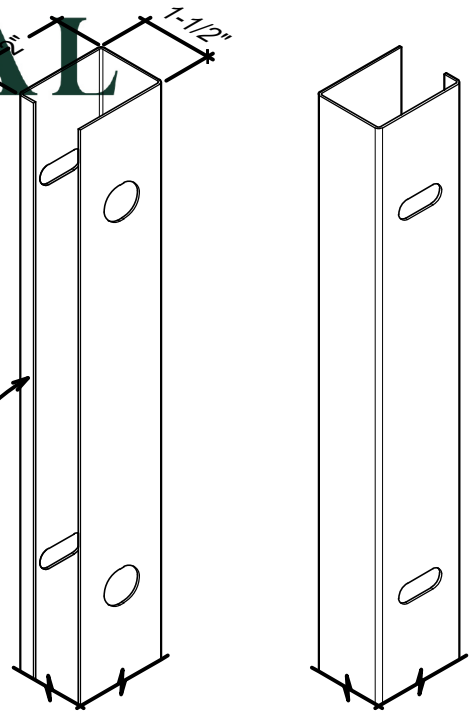

FRONT VIEW

BACK VIEW

**B** CI-Girt™ 150  
SCALE: NTS

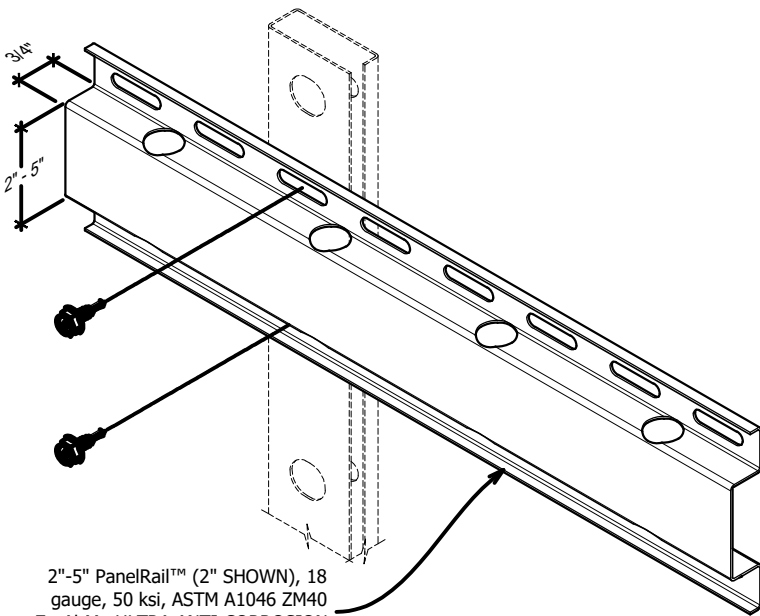

**C** PanelRail™  
SCALE: NTS

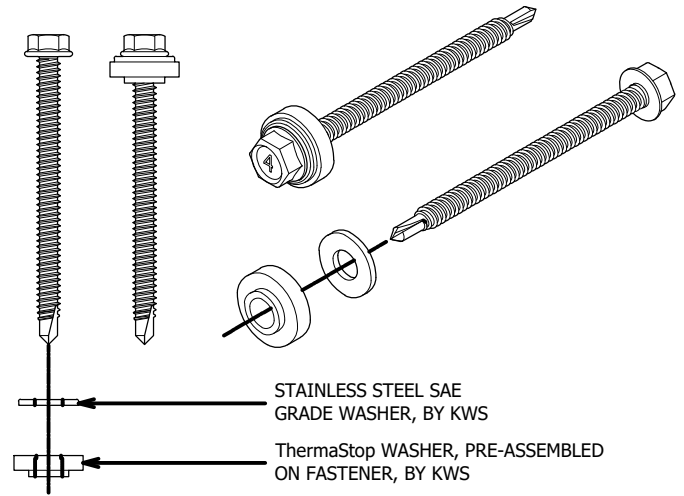

**C** ThermaStop™ THERMAL ISOLATION WASHER ASSEMBLY  
SCALE: NTS

16 GAUGE RAILS, FACTORY COATED RAILS & STAINLESS STEEL (304) AVAILABLE

\*MAXIMUM ALLOWABLE SPACING AND DEAD LOAD (WEIGHT OF CLADDING) IS BASED ON THE TOTAL LOAD (DEAD + LIVE) ACTING ON THE ASSEMBLY, BRACKETS AND CONNECTIONS

## 18 ISOMETRIC VIEW OF COMPONENTS BY KWS SCALE: NTS

10/16/2016

THESE GUIDE DETAILS ARE PROVIDED FOR INFORMATION ONLY AND OUTLINE GENERAL/TYPICAL REQUIREMENTS FOR THE ATTACHMENT SYSTEM. PROJECT SPECIFIC ENGINEERING WILL ADDRESS STRUCTURAL ATTACHMENT (i.e. FASTENING PATTERN, ETC.). CONTACT KWS FOR FURTHER DETAILS. ALL IMPLIED WARRANTIES INCLUDING MERCHANTABILITY & FITNESS FOR A PARTICULAR PURPOSE ARE EXPRESSLY EXCLUDED.

Please visit us online for more information & CAD files  
www.knightwallsystems.com  
© Knight Wall Systems Deer Park, WA - 1.855.KWS.WALL  
PATENT US 8,429,866 B2, OTHERS PENDING - Drawn by: BN

## KNIGHT WALL HCI™ System (HCI-Girt ONLY) RAINSCREEN ATTACHMENT

6200 Tomken Rd Mississauga, ON - L5T 1X7 - Canada  
1-855-344-4500 | www.TropicalForestProducts.com | info@tropicalforestproducts.com  
© All Rights Reserved - Tropical Forest Products 2023